

RETINOIDS IN DERMATOLOGY: FUNCTIONAL ACTIVITY AND PROSPECTS OF SYNTHETIC ANALOGUES

V. B. KOVTUN¹, O. G. SIDORENKO², M. D. KHOMIAKOVA³, I. A. LEVANDOVSKIY¹

¹National Technical University of Ukraine
“Igor Sikorsky Kyiv Polytechnic Institute”

²LLC “PHARMA INTERNATIONAL GROUP 2”, Kyiv, Ukraine

³Gimnasium “Akademiiia”, Kyiv, Ukraine

E-mail: lia198@bigmir.net

Received 07.06.2020

Revised 03.08.2020

Accepted 30.08.2020

The aim of the work was to analyze and summarize information on the functional activity of known retinoids, as well as to determine the directions of their modification and prospects for the use of their synthetic analogues in dermatology.

The literature on retinoids metabolism stages in the human body, the mechanisms of their action and the properties that determine their use in various medical fields was considered and analyzed. Information on dermatological diseases treatment with natural retinoids and their synthetic analogues was summarized.

The modern classification of retinoids based on the peculiarities of their chemical structure and functional activity is given, the relationship between these characteristics and the direction of use of such drugs in dermatology and cosmetology is shown.

Prospects for the practical application of synthetic retinoids represented mainly by polyaromatic compounds are due to their higher stability and efficiency, as well as reduced irritant effect due to selectivity for nuclear receptors.

Key words: retinoids, synthetic analogues of retinoids, mechanisms of biological activity, nuclear receptors of retinoids, dermatology.

Retinoids, compounds of vitamin A group that trigger a number of important biochemical processes in cells due to their unique ability to penetrate the cell nucleus and control DNA transcription, play a leading role in the topical or systemic treatment of skin diseases [1]. Vitamin A (retinol) ensures the normal existence of skin epithelial cells, mucous membranes of the eyes, respiratory, urinary and digestive tracts; participates in redox processes, protein synthesis regulation, promotes normal metabolism, cell and subcellular membranes function, plays an important role in bones and teeth as well as adipose tissue formation; it is necessary for the growth of new cells and slows down the aging process [2–4].

Areas of retinol use in dermatology are diverse due to its biological activity. Due to its elastostimulating and elastoprotective action, it is successfully used in anti-aging drugs. Angiogenesis and melanogenesis inhibition and Langerhans cell population recovery allow its successful use in photoaging, couperosis, hypermelanosis. Retinol also promotes keratolytic processes, activates the synthesis of epidermal lipids and restores the epidermal barrier. The sebostatic, regenerating and antibacterial retinol action allows its use for acne treatment [1, 5, 6].

However, the use of retinol itself, even in therapeutic doses, is often accompanied by skin irritation and dermatitis, which does not allow properly detecting the therapeutic effect. After

the development of new synthetic or modified retinoids with altered chemical structure, this retinol defect was mainly overcome and retinoids became widely used in dermatology because of their ability to influence epithelial differentiation and skin tumors inhibition. Therefore, given the relevance of new synthetic analogues of retinol creation with improved pharmacological characteristics, the purpose of this review was to analyze and summarize the functional activity of known retinoids, as well as to identify promising areas for their modification and use in dermatology.

Retinoids metabolism in human organism and cells

The functional activity of retinol is associated with its metabolism in the human body: entering the body, including in the form of β -carotene or retinol ethers, it is used in the form of retinol, retinal and retinoic acid. Retinol and β -carotene in the intestine are converted to *trans*-retinol and stored for some time in the liver, where they are transformed into retinol ethers. Retinol is excreted from the liver and transported by retinol-binding protein to blood plasma [5, 6].

There are β -ion ring, isoprenoid side chain and terminal functional group in the structure of retinol. The β -ion ring is responsible for the specific interaction with the transport retinol-binding protein, and the polar end group is able to be converted to ether (forming retinol palmitate) or oxidized to aldehyde (retinal) and then to the carboxyl group (with the formation of retinoic acid).

Biological activity of most retinol metabolites is not detected. They are probably eliminated quickly, however, some compounds, such as retinoyl glucuronide, may retain 30 to 100% of *trans*-retinoic acid biological activity. Thus, retinol, retinal and retinoic acid are not the only possible biologically active forms of vitamin A.

When administered in physiological doses, up to 80% of vitamin A after absorption in the intestine or epithelium enters the liver and accumulates in hepatocytes, star-shaped and Kupffer cells in combination with lipoprotein. Retinol enters the blood in combination with retinol-binding protein, which protects the vitamin from renal filtration, and cells from its active action. The entry of retinol into the blood depends on the rate of retinol-binding protein synthesis and is controlled by adrenal hormones, estrogen and growth hormone [7].

In human skin, *trans*-retinol is metabolized to at least four important products: retinol ethers, 14-hydroxy-4,14-retro-retinol, *trans*-3,4-didehydroretinol and *trans*-retinoic acid (TRA). Among these metabolites, the concentration of retinol ether is the highest. Retinol ethers function as a form of retinol storage, and their hydrolysis yields free retinol. Topical treatment of the skin with *trans*-retinol or *trans*-retinolaldehyde has the best result: the content of retinol ethers in the cells increases more than 10 times [8].

Physiological functions of the skin are determined also by lecithin-retinol acyltransferase (LRAT), which catalyzes the synthesis of retinol ethers [8, 9]. Induction of LRAT increases retinoids activity and retinol ether formation and reduces TRA biosynthesis [10]. Under these conditions, inhibition of LRAT restores TRA synthesis by phenylmethylsulfonyl fluoride. Thus, TRA synthesis decrease in the skin occurs more due to increased competition for *trans*-retinol between LRAT and retinol dehydrogenase than when TRA synthesis is inhibited due to suboptimal physicochemical factors.

Regulation of LRAT activity by retinoids provides a mechanism of TRA synthesis autoregulation (Fig. 1). At a sufficient concentration of retinoids, esterification of *trans*-retinol is induced and the synthesis of TRA is reduced, while in conditions of retinoid deficiency the opposite situation occurs. Introduced from outside TRA bound with cellular retinol-binding protein (CRBP) in keratinocytes *t*ROL, is catalyzed by lecithin retinol acyltransferase (LRAT) or sequentially oxidized to retinaldehyde (*t*RAL) and catalyzed by retinoldehydrogenase (*t*ROLDH), and then to TRA which is catalyzed by retinaldehydrogenase (*t*RALDH). TRA binds to cellular retinol-binding protein-II (CRBP-II) and is hydroxylated by *t*RA 4-hydroxylase to 4-hydroxy-TRA (4-OH *t*RA), which binds and activates RAR- γ and RXR- α . Activation of RAR- γ /RXR- α stimulates the transcription of genes containing the corresponding *t*RA elements (RARE) in their promoters. *t*RA induces CRBP, CRABP-II, LRAT and *t*RA4-OH in human skin, and thus regulates its own content. CRBP and CRABP-II contain RAREs in their promoters, and therefore their transcription is directly stimulated by RAR- γ /RXR- α receptors [11].

With hypovitaminosis A, proliferation, differentiation and duration of cell life cycles change [2]. The epidermis responds to vitamin A deficiency by cementing the

growth zone, nuclei polymorphism, horny layer thickening [12]. On the example of the skin, horns, trachea, liver, it is shown that the lack of vitamin A in the body is accompanied by proliferative activity of epithelial cells inhibition.

In the early stages of hypovitaminosis, in the epithelium there is an increase in the duration of S- and shortening of G2-periods [13]. Cell differentiation is inhibited and their functional activity decreases. On small bowel explants, it was found that the addition of vitamin A to the culture fluid reproduces the functional activity of goblet cells by replenishing their population from progenitor cells. Such results were obtained for the secretory cells of the epithelium and glands of the digestive system [12].

Moderately elevated doses of vitamin A stimulate keratinocyte proliferation in both *in vitro* models (skin epithelial culture and epidermal explants) and *in vivo* in experimental animals and humans. For example, *trans*-retinoic acid (TRA) stimulates keratinocyte proliferation for 4 days, increasing the number of epidermal cell layers and increasing the thickness of the epidermis [14, 15] (Fig. 2, image on the right). TRA also causes a characteristic barrier compaction and widening of the gaps between keratinocytes.

Herewith the increase in mitotic activity of cells occurs in parallel with the increase in the ability of the population to synthesize DNA. This effect is not associated with increased

DNA repair, and is determined by the increase in the number of cells responsible for the onset of DNA replication. This dependence applies to most skin epithelium. With total dose of vitamin A increasing, the changes may not be limited to this, but lead to the appearance of metaplastic epithelium areas [13].

To dissolve, protect and detoxify retinoids in extracellular and intra-abdominal media, *trans*-retinol, *trans*-retinal and *trans*-retinoic acid bind to specific proteins [9, 16].

The most suitable extracellular retinoid-binding proteins are:

- retinol-binding protein 4 ((i) *retinol-bindingprotein 4 — RBP4*), which binds mainly *trans*-retinol (adducts stabilization through transthyretins association reduces renal filtration of retinoids);
- *interphotoreceptor matrix retinoid-binding protein ((ii) — IRBP)* — binds mainly to 11-*cis*-retinal, 11-*cis*-retinol and *trans*-retinol;
- epididymal retinoid-binding protein ((iii) — *ERBP*) — binds mainly *trans*-retinol;
- β -trace (*iv*) — binds mainly *trans*- and 9-retinoic acid, as well as *trans*- and 13-*cis*-retinal;
- serum albumin (*v*) — binds mainly *trans*-retinoic acid;
- very low density lipoproteins, low density lipoproteins and high density lipoproteins — bind retinol ethers and esters.

Intracellular (cellular) retinoid binding proteins (*CRBPs*) are:

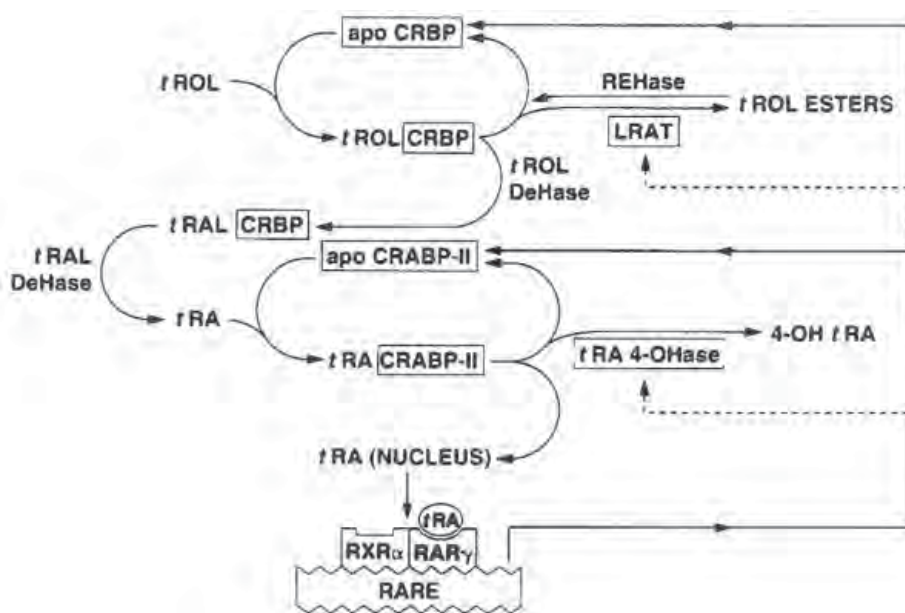

Fig. 1. Autoregulation of *trans*-retinoic acid metabolism in the skin [10]; LRAT — lecithin retinol acyltransferase; CRBP — cellular retinol-binding protein; CRBP-II — cellular retinol-binding protein II

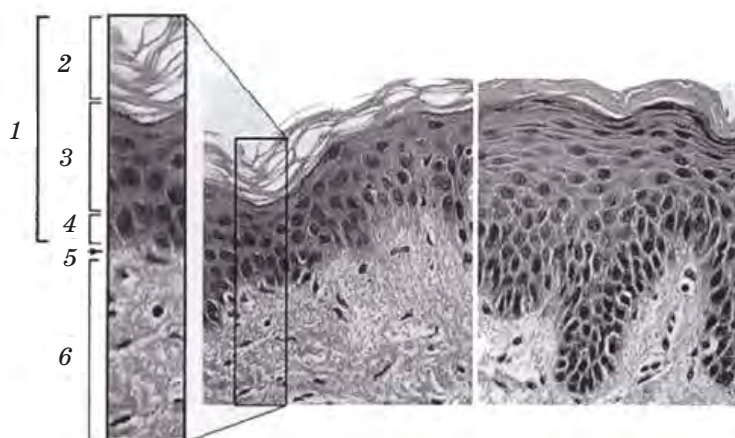

Fig. 2. Histology of human skin under normal conditions (left) and treated with 0.1% TRA (right) [14]:

1 — epidermis (keratinocytes); 2 — dead barrier; 3 — suprabasal keratinocyte layer;
4 — basal keratinocyte layer; 5 — dermo-epidermal junction (basal membrane zone); 6 — dermis

- CRBP1 and CRBP2 — bind *trans*-retinal and *trans*-retinol;
- proteins that bind retinoic acid (*cellular RA-binding protein CRABP*) CRABP1 and CRABP2;
- (III) CRBP3 and CRBP4 — bind *trans*-retinol only,
- (IV) cellular retinal-binding protein (*CRALBP*) — binds *trans*-retinal only.

All these proteins play an important role in the transport and metabolism of retinoids, especially in their scarcity.

Retinoids properties and clinical use

Retinoids are vitamin A-like class of chemical compounds that can cause specific biological responses as a result of the binding and activation of retinoic acid receptors. Retinoids, as well as synthetic derivatives, which differ significantly from the isoprene structure of natural vitamin A, act similarly, namely through the activation of nuclear retinoid receptors they regulate the processes of proliferation, differentiation and intercellular interaction [17–19].

Within the class of retinoids, there is significant heterogeneity both in terms of properties and in terms of results of clinical use [20–22]. They are involved in the regulation of gene transcription by activating receptors located in the nucleus or bind to transcription factors (nuclear receptors), and then the formed complex “ligand-receptor” joins the promotor site of the corresponding gene, resulting in the synthesis of substances that cause pharmacological action (both therapeutic and side effects). Retinoids contribute

to the normalization of cells terminal differentiation, inhibit the hyperproliferation of the epithelium in the excretory ducts of the sebaceous glands, the formation of detritus. In addition, these drugs have anti-inflammatory and immunotropic effects in the treatment of open wounds by inhibiting the inflammatory mediator leukotriene B4 [19].

Thus, when applied externally and systemically, retinoids have a sebostatic, anti-inflammatory, kerato- and immuno-modulating effect, activate the regeneration processes in the skin, and stimulate the synthesis of mucopolysaccharides and glycosaminoglycans (Fig. 3).

The first generation of retinoids includes retinol, retinol acetate, retinol palmitate, retinal, tretinoin, isotretinoin, alitretinoin (Table). The first-generation retinoids are widely used to treat acne, as well as in anti-aging cosmetics. The second generation includes etretinate and acitretin. These retinoids are used as systemic drugs to treat psoriasis and dermatoses. The third generation of retinoids is represented by polyaromatic compounds (arotinoid acid, adapalene, tazarotene and bexarotene) and is used in dermatology, as well as in oncological practice [22].

Alitretinoin or *9-cis-retinoic acid* is a form of vitamin A, developed by Ligand Pharmaceuticals company, is used as an antitumor drug as well as in the treatment of severe persistent eczema of the hands [23]. *Tretinoin* is a retinoid used in dermatology since the 1960s, but its efficacy in the treatment of photoaging was first demonstrated by Kligman and colleagues only in 1984: the treatment of photoaging

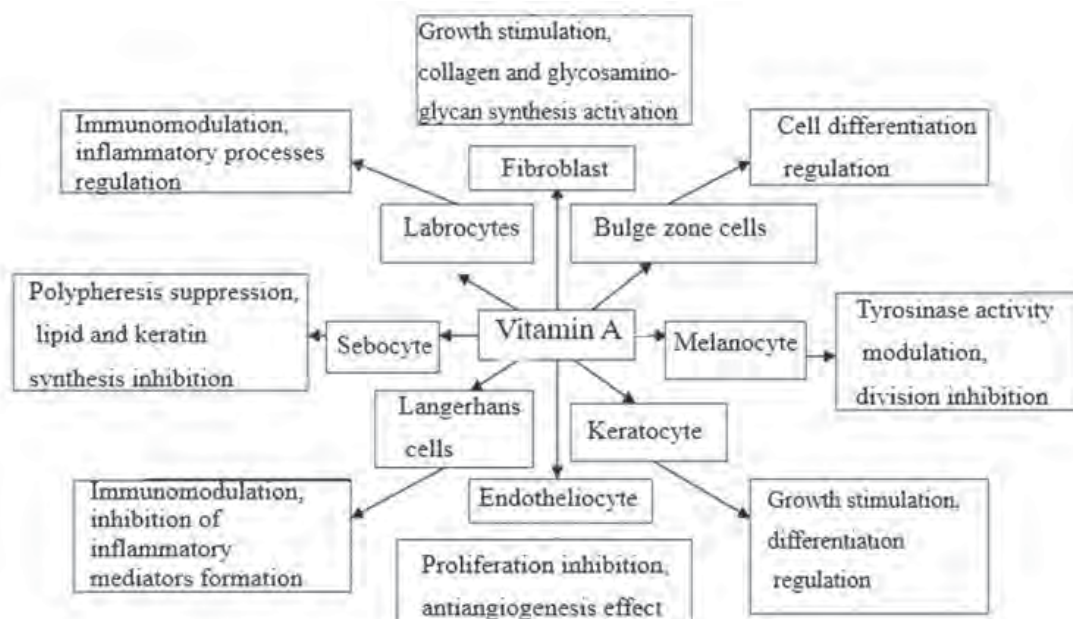
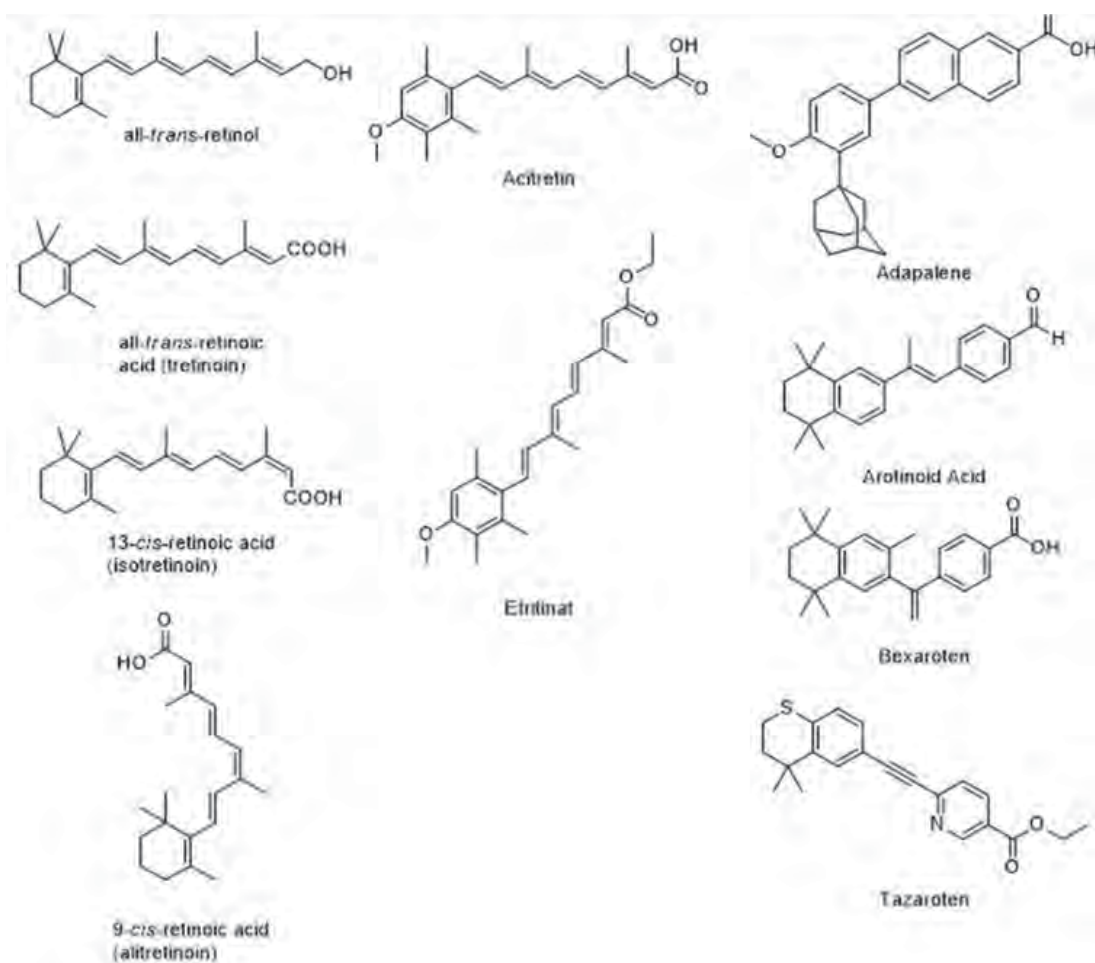

Fig. 3. Targets and biological effects of vitamin A compounds

Table. Representatives of the I-III generation of retinoids [18, 19, 22]
 The I generation The II generation The III generation



of mouse skin with tretinoin for 10 weeks resulted in significant recovery of the area with new collagen which correlated with the smoothing of wrinkles. This interesting observation prompted researchers to study the potential of tretinoin in the treatment of photoaging. Later, the molecular basis of this observation became clear [14]. It was found that pre-treatment of UV-irradiated photoaging skin with 0.1% solution of tretinoin leads to complete blockade of interstitial collagenase and gelatinase synthesis, preventing the collagen degradation.

Isotretinoin is a biologically active form of vitamin A, can be synthesized in the body. Isotretinoin does not directly bind to nuclear retinoic acid receptors (RAR or RXR). It is rapidly converted to tretinoin and other substances-ligands of nuclear retinoic acid receptors and regulates gene expression, which causes changes in protein synthesis (depending on the state of the tissue it may be either induction or inhibition). It has anti-inflammatory, keratolytic and antiseborrheic action, inhibits the terminal differentiation of keratinocytes, stimulates regenerative processes [24].

Acitretin is a synthetic aromatic analogue of retinoic acid that has no hepatotoxic, mutagenic or carcinogenic effects. Clinical studies have confirmed that in psoriasis and keratinization disorders, acitretin normalizes the proliferation, differentiation and keratinization of epidermal cells, and its side effects, in general, are quite acceptable. The effect of the drug is symptomatic, and the mechanism of action remains incompletely studied [25].

Etretinate is a synthetic substance derived from retinoic acid (ethyl ester of acitretin) with a bioavailability of 50% when it is taken orally [26]. Etretinate undergoes a number of metabolic changes, including hydrolysis by esterases in the liver and intestine, the formation of conjugates of 13-*cis*-acitretin and dimethylated acitretin derivatives, which are further excreted in bile and urine. Etretinate is used for psoriasis, ichthyosis, Darier's disease and some other skin diseases.

Arotinoid acid is one of the most potent synthetic retinoids, acting as a selective retinoic acid receptor (RAR) agonist. It plays the role of antitumor and antiteratogenic agent, is a part of benzoic acids, retinoids and naphthalenes, has the highest affinity for human skin and cellular retinoid-binding protein (CRBP) [18]. Another advantage of

this substance is its slow destruction in the cell, as well as the lack of retinoid dermatitis, which often occurs with the use of retinoids of previous generations. Retinoid dermatitis is a well-known side effect of synthetic retinoids, but usually occurs in combination with the symptoms of psoriasis, and obviously hinders the achievement of therapeutic results in some patients.

Therefore, one of the important advantages of arotinoid acid over acitretin and etretinate is the absence of mucosal irritation and retinoid dermatitis at potentially therapeutic doses. This allowed it to be used not only in dermatology for the treatment of severe forms of acne and dermatoses, but also in rheumatology, in the treatment of cancer and in other fields [21].

The search for new retinoids, safer and more potent than available compounds, has led to the development of arotinoids [27]. In previous clinical trials, the arothinoid acid ethyl ester was found to be highly effective in the treatment of severe and persistent retinoid dermatoses. Using mouse embryonic cells and keratinocyte cells as experimental models, it was shown that arothinoid ethyl ester affects the differentiation of epithelial cells *in vivo* and *in vitro*. It stimulates epidermis proliferation in both embryos and adult mice. However, it inhibits the differentiation of the embryonic epidermis, enhances the differentiation of the epidermis in adults and causes a decrease in the content of cyclic AMP in keratinocytes stimulated by cholera toxin.

Adapalene is considered a third-generation synthetic retinoid that contains naphthoic acid. Unlike retinoic acid, adapalene has selectivity for the nuclear retinoic acid receptor (RAR). It aims at pathological peeling of the skin, modulates cell differentiation and has anti-inflammatory properties. In addition, due to its selectivity to receptors, it causes less skin irritation and has been used successfully in the treatment of acne [28]. Thus, a two-center randomized placebo-controlled masked study with parallel groups of 83 patients with actinic keratosis and solar lentigo and other symptoms of photoaging was performed to assess the therapeutic potential of adapalene (0.1% or 0.3%). After 9 months of treatment up to 60% of patients had improved cell state and reduced epidermal melanin.

As expected, adapalene was well received by patients, and therefore it can be used as an adjunct to the treatment of photoaging mainly in chronic intolerance to conventional

retinoids. Adapalene (a derivative of naphthoic acid) is an example of new substances with specified pharmacological properties and clinical effects: molecule stability and anti-inflammatory action increasing, efficiency maintaining, skin irritation minimizing.

The exact mechanism of adapalene action is unknown, but it is assumed that, when applied topically, it normalizes the differentiation of follicular epithelial cells and keratinization, preventing the formation of micro-comedones, similar to the action of natural retinoids. Unlike retinoic acid, adapalene binds to specific nuclear retinoic acid receptors (RARs) and does not interact with so-called cytosolic retinoic acid binding proteins (CRABPs) [29].

Tazarotene is a new acetylene retinoid effective in the topical treatment of psoriasis and acne, which along with acitretin are currently the only FDA approved retinoids for the treatment of psoriasis. Tazarotene acts on RAR and RXR receptors, altering the expression of a gene that stimulates inflammatory cytokines and keratinocyte proliferation is inhibiting [30]. Tazarotene is rapidly metabolized to the active metabolite of tazarotenoic acid. Due to its rigid poly-aromatic framework, it does not undergo isomerization or conformational changes in the skin. Sefton and colleagues (2006) were the first who conduct an experimental two-way randomized trial to evaluate the effectiveness of 0.1% tazarotene in 10 healthy women with moderate photoaging of forearm skin. At the end of the 12th week, in the group treated with tazarotene there was a significant reduction in pigment spots, thin folds and roughness of the skin, and histological examination showed a decrease in keratinocytes atypia and their polarity restoration.

Tazarotene supports the outcome of treatment and plays a significant role in post-therapy. The most common side effect is topical irritation, which limits its role as the only mean for psoriasis treatment. Efficacy is increased by combination with topical corticosteroids (TCS). A new fixed combination is currently available: tazarotene and halobetazole for topical application, which provides synergistic efficacy for both rapid treatment and long-term post-therapy.

Bexarotene is a selective retinoid X receptor (RXR) agonist. It binds and activates RXRs, which function as ligand-activated transcription factors that control

gene expression. This leads to cell growth modulation, apoptosis and differentiation. Bexarotene is used to treat diabetes and various malignancies [31, 32]. Bexarotene, as one of the last synthesized nuclear X retinoid receptor agonists (RXR), is one of the recently proposed therapeutic agents for the treatment of cognitive deficits in Alzheimer's disease [32]. At the molecular level, bexarotene, in addition to stimulating nuclear X retinoid receptors, is also able to block calcium-permeable ion channels formed by β -amyloid due to its ability to bind to it. The protective effect of bexarotene against the irritant effect of β -amyloid can also occur through insulin-mediated signaling pathways [33].

Retinoids biosynthesis prospects

The study of the biochemical properties, as well as retinoid-converting enzymes active sites and mechanisms of action in animals and bacteria, including retinol dehydrogenase, alcohol dehydrogenase, aldo-ketoreductase and aldehyde dehydrogenase, made it possible to propose the production of retinoids using genetically engineered (metabolically constructed) bacterial cells [34–36].

Retinal (a precursor of retinoids) is prepared using β -carotene 15,15'-mono (di)oxygenase (BCM(D)O) from β -carotene, which is synthesized from isoprenenoid building blocks of isopentenylidiphosphate (IPP) and dimethylallyldiphosphate (DMAPP). The possibility of retinoids obtaining using genetically engineered *Escherichia coli*, which expresses exogenous BCM(D)O, and mevalonate pathway of building blocks synthesis in combination with a two-phase culture system using dodecane [35] has been shown. Among the problems of biosynthesis is a significant level of retinoids intracellular degradation, to prevent which a two-phase cultivation system with dodecane was used, which allowed to increase the yield of the product 68 times. In this study, 136 mg/l of retinoids consisting of retinal (67 mg/l), retinol (54 mg/l) and retinyl acetate (15 mg/l) were successfully obtained and the potential of *Escherichia coli* for microbial retinoid synthesis was demonstrated.

The possibility of biotechnological production of *all-trans-retinol* by recombinant bacterial alcohol dehydrogenase (ADH) from *Kangiella koreensis* was first reported [36]. Purified ADH as a 40 kDa dimer with a specific

activity of 21.3 nmol min⁻¹ mg⁻¹ was specific for *all-trans*-retinol using NADH as a cofactor. The optimal conditions for *trans*-retinol obtaining were determined: pH 6.5, 60 °C, 2 g/l of the enzyme, 2.2 mg/l of *all-trans*-retinal in the presence of 5% of methanol, 1% of hydroquinone and 10 mM of NADH. Under optimized conditions, the synthesis of *all-trans*-retinol reached 600 mg/l in 3 h, which indicates the prospects of the proposed method.

The functional activity of retinoids has an extremely wide range: participation in redox processes, protein synthesis regulation, the work of cell and subcellular membranes, normal metabolism promotion, bones and adipose tissue formation.

By interaction with receptors in the nucleus of target cells, retinoids bind to DNA fragments and stimulate gene transcription, revealing a hormone-like effect. Retinol is needed to maintain and repair the epithelial tissues that make up the skin and mucous membranes, and is used in the treatment of almost all skin diseases.

Promising synthetic retinoids are mainly polyaromatic compounds, which obviously

should be given special attention by both synthetic chemists and pharmacologists. Among the representatives of the third generation of these compounds, arotinoids should be noted which have been shown to be highly effective in the treatment of severe and persistent dermatoses, and their reduced irritant effect is due to selectivity for nuclear receptors. Due to the presence of a rigid polyaromatic framework, arotinoids do not undergo isomerization or conformational changes in the skin, which provides increased efficiency and stability of their drugs.

The review of examples of numerous dermatological diseases that can be treated using synthetic analogues of natural retinoids determines their importance for the means of this profile development. And their recent functional activity against tumors, diabetes and cognitive deficits clearly indicates a broader prospect for their medical use.

The study was supported by a project funded by the Ministry of Education and Science of Ukraine.

No potential conflict of interest was reported by the authors.

REFERENCES

1. Theodosiou M., Laudet V., Schubert M. From carrot to clinic: an overview of the retinoic acid signaling pathway. *Cell. Mol. Life Sci.* 2010, V. 67, P. 1423–1445. <https://doi.org/10.1007/s00018-010-0268>
2. Blomhoff R., Blomhoff H. K. Overview of retinoid metabolism and function. *J. Neurobiol.* 2006, V. 66, P. 606–630. <https://doi.org/10.1002/neu.20242>
3. Jager C. Vitamins and Brain Health. *Vitamins & Trace Elements.* 2013, 01 (01). <https://doi.org/10.3390/nu8020068>
4. Keys S., Zimmerman W. Antioxidant Activity of Retinol, Glutathione, and Taurine in Bovine Photoreceptor Cell Membranes. *Experimental Eye Res.* 1999, 68 (6), 693–702. <https://doi.org/10.1006/exer.1999.0657>
5. Tee E., Lim C. The analysis of carotenoids and retinoids: A review. *Food Chemistry.* 1991, 41 (2), 147–193. <https://doi.org/10.1021/jf00108a049>
6. Khalil S., Bardawil T., Stephan C., Darwiche N., Abbas O., Kibbi A., Nemer G., Kurban M. Retinoids: a journey from the molecular structures and mechanisms of action to clinical uses in dermatology and adverse effects. *J. Dermatol. Treatment.* 2017, 28 (8), 684–696. <https://doi.org/10.1080/09546634.2017.1309349>
7. Chaves G., Peres W., Gonçalves J., Ramalho A. Vitamin A and retinol-binding protein deficiency among chronic liver disease patients. *Nutrition.* 2015, 31 (5), 664–668. <https://doi.org/10.1016/j.nut.2014.10.016>
8. Elder J., Åström A., Pettersson U., Tavakkol A., Krust A., Kastner P., Chambon P., Voorhees J. Retinoic Acid Receptors and Binding Proteins in Human Skin. *J. Investigative Dermatol.* 1992, 98 (6), S36–S41. <https://doi.org/10.1111/1523-1747.ep12462180>
9. Daly A., Rees J., Redfern C. Nuclear Retinoic-Acid-Binding Proteins and Receptors in Retinoic-Acid-Responsive Cell Lines. *Pathobiol.* 1989, 57 (6), 339–345. <https://doi.org/10.1159/000163547>
10. Fisher G., Talwar H., Xiao J., Datta S., Reddy A., Gaub M., Egly C., Chambon P., Voorhees J. Immunological and functional quantitation of nuclear retinoid X (RXR) and retinoic acid (RAR) receptor proteins in human epidermis *in vivo*: High levels of RXRS and RAR- γ , low levels of RAR- α , and absence of RAR- β . *J. Dermatol. Sci.* 1993, 6 (1), 53.
11. Dawson M. I., Zhang X., Hobbs P. D., Jong L. Synthetic retinoids and their usefulness in

- biology and medicine. In: Livrea M. A. (eds) Vitamin A and Retinoids: An Update of Biological Aspects and Clinical Applications. 2000MCBU. *Molecular and Cell Biology*. Updates. Birkhäuser, Basel. <https://doi.org/10.1007/978-3-0348-8454-9/>
12. Båvik C., Peterson P., Eriksson U. Retinol-Binding Protein Mediates Uptake of Retinol to Cultured Human Keratinocytes. *Experimental Cell Res.* 1995, 216 (2), 358–362. <https://doi.org/10.1006/excr.1995.1045>
 13. Tanumihardjo S. Can Lack of Improvement in Vitamin A Status Indicators Be Explained by Little or No Overall Change in Vitamin A Status of Humans? *J. Nutrition.* 2001, 131 (12), 3316–3318. <https://doi.org/10.1093/jn/131.12.3316>
 14. Fisher G., Voorhees J. Molecular mechanisms of retinoid actions in skin. *FASEB J.* 1996, 10 (9), 1002–1013. <https://doi.org/10.1096/fasebj.10.9.8801161>.
 15. Weiss J. Topical Tretinoin Improves Photoaged Skin. *JAMA.* 1988, 259 (4), 527. Baker M. From skin cell to stem cell. *Nature Reports Stem Cells.* 2007.
 16. Lohnes D., Mark M., Mendelsohn C., Doll P., Decimo D., LeMeur M., Dierich A., Gorry P., Chambon P. Developmental roles of the retinoic acid receptors. *J. Steroid Biochem. Mol. Biol.* 1995, 53 (1–6), 475–486. [https://doi.org/10.1016/0960-0760\(95\)00094-G](https://doi.org/10.1016/0960-0760(95)00094-G)
 17. Molin S. C., Ruzicka T. Retinoids. In: John S., Johansen J., Rustemeyer T., Elsner P., Maibach H. (eds) *Kanerva's Occupational Dermatology.* 2020. Springer, Cham.
 18. Harrison E. H., Curley R. W. Carotenoids and Retinoids: Nomenclature, Chemistry, and Analysis. In: Asson-Batres M., Rochette-Egly C. (eds) *The Biochemistry of Retinoid Signaling II. Subcellular Biochemistry.* 2016, V. 81. Springer, Dordrecht.
 19. Chandraratna R. Future trends: A new generation of retinoids. *J. American Academy of Dermatol.* 1998, 39 (4), S149–S152.
 20. Kawaguchi R., Zhong M., Kassai M., Ter-Stepanian M., Sun H. Differential and Isomer-Specific Modulation of Vitamin A Transport and the Catalytic Activities of the RBP Receptor by Retinoids. *J. Membrane Biol.* 2013, V. 246, P. 647–660. <https://doi.org/10.1007/s00232-013-9578-z>
 21. Beckenbach L., Baron J. M., Merk H. F., Löffler H., Amann P. M. Retinoid treatment of skin diseases. *Eur. J. Dermatol.* 2015, V. 25, P. 384–391. <https://doi.org/10.1684/ejd.2015.2544>
 22. Marks R. Retinoids for the future: developing a new generation of receptor-selective retinoids. *J. European Academy of Dermatol. Venerol.* 1995, 5 (1), S189.
 23. Ruzicka T., Larsen F., Galewicz D., Horváth A., Coenraads P., Thestrup-Pedersen K. Oral Alitretinoin (9-cis-Retinoic Acid) Therapy for Chronic Hand Dermatitis in Patients Refractory to Standard Therapy. *Archives Dermatol.* 2004, 140 (12).
 24. Stratigos A., Katsambas A. The Role of Topical Retinoids in the Treatment of Photoaging. *Drugs.* 2005, 65 (8), 1061–1072.
 25. Guenther L., Kunyetz R., Lynde C., Sibbald R., Toole J., Vender R. Acitretin Use in Dermatology. *J. Cutaneous Medicine and Surgery.* 2017, 21 (3 suppl), 2S–12S.
 26. Larsen F., Jakobsen P., Larsen C., Kragballe K., Nielsen-Kudsk F. Pharmacokinetics of Etretin and Etretinate during Long-Term Treatment of Psoriasis Patients. *Pharmacol. Toxicol.* 1988, 62 (3), 159–165.
 27. Shi-Jun Shan, Yuan-Hong Li, Guowei Zhang, Ting Xiao, Changping Li, Huachen Wei, Hong-Duo Chen. Treatment of palmoplantar pustulosis with arotinoid ethylester. *Europ. J. Dermatol.* 2009, 19 (5), 474–477. <https://doi.org/10.1684/ejd.2009.0727>
 28. Loss M. J., Leung S., Chien A., Kerrouche N., Fischer A., Kang S. Adapalene 0.3% Gel Shows Efficacy for the Treatment of Atrophic Acne Scars. *Dermatol. Therapy. (Heidelberg).* 2018, V. 8, P. 245–257. <https://doi.org/10.1007/s13555-018-0231-8>
 29. Abe M., Inoue C., Yokoyama Y., Ishikawa O. Successful Treatment of Darier's Disease with Adapalene Gel. *Pediatric Dermatol.* 2010, 28 (2), 197–198.
 30. Frances L., Pascual J., Leiva-Salinas M., Betlloch I. Extramammary Paget disease successfully treated with topical imiquimod 5% and tazarotene. *Dermatol. Therapy.* 2013, 27 (1), 19–20.
 31. Cao H., Bissinger R., Umbach A., Gawaz M., Lang F. Effect of Bexarotene on Platelet Activation and Apoptosis. *Cellular Physiol. Biochem.* 2017, 42 (2), 838–847.
 32. Lewis D., Huang S., Duvic M. Oral bexarotene for post-transplant cutaneous T-cell lymphoma. *Dermatol. Therapy.* 2017, 30 (5), e12524.
 33. Heo J., Jung T., Lee S., Kim H., Choi G., Jung M. Effect of bexarotene on differentiation of glioblastoma multiforme compared with ATRA. *Clin. Experimental Metastasis.* 2016, 33 (5), 417–429.

РЕТИНОЇДИ В ДЕРМАТОЛОГІЇ: ФУНКЦІОНАЛЬНА АКТИВНІСТЬ ТА ПЕРСПЕКТИВИ СИНТЕТИЧНИХ АНАЛОГІВ

В. Б. Ковтун¹, О. Г. Сидоренко²,
М. Д. Хомякова³, І. А. Левандовський¹

¹Національний технічний університет
України

«Київський політехнічний інститут
імені Ігоря Сікорського»

²ТОВ «ФАРМА ІНТЕРНЕШНЛ ГРУП 2»,
Київ, Україна

³Гімназія «Академія», Київ, Україна

E-mail: lia198@bigmir.net

Метою роботи було проаналізувати й узагальнити інформацію стосовно функціональної активності відомих ретиноїдів, а також визначити напрями їх модифікації та перспективи застосування в дерматології їхніх синтетичних аналогів.

Розглянуто та проаналізовано дані літератури щодо етапів метаболізму ретиноїдів в організмі людини, механізмів їхньої дії та властивостей, що зумовлюють застосування їх у різних медичних галузях. Узагальнено інформацію щодо лікування дерматологічних захворювань природними ретиноїдами та їхніми синтетичними аналогами.

Наведено сучасну класифікацію ретиноїдів, засновану на особливостях їхньої хімічної структури та функціональної активності, показано взаємозв'язок цих характеристик і засобів використання таких препаратів у дерматології та косметології.

Перспективи практичного застосування синтетичних ретиноїдів, що представлені переважно поліароматичними сполуками, зумовлені їхньою вищою стабільністю та ефективністю, а також зниженою подразнювальною дією завдяки вибірковості до ядерних рецепторів.

Ключові слова: ретиноїди, синтетичні аналоги ретиноїдів, механізми біологічної активності, ядерні рецептори ретиноїдів, дерматологія.

РЕТИНОИДЫ В ДЕРМАТОЛОГИИ: ФУНКЦИОНАЛЬНАЯ АКТИВНОСТЬ И ПЕРСПЕКТИВЫ СИНТЕТИЧЕСКИХ АНАЛОГОВ

В. Б. Ковтун¹, А. Г. Сидоренко²,
М. Д. Хомякова³, И. А. Левандовский¹

¹Национальный технический университет
Украины

«Киевский политехнический институт
имени Игоря Сикорского»

²ООО «ФАРМА ИНТЕРНЕШНЛ ГРУП 2»,
Киев, Украина

³Гимназия «Академия», Киев, Украина

E-mail: lia198@bigmir.net

Целью работы был анализ и обобщение информации о функциональной активности известных ретиноидов, а также определение направлений их модификации и перспектив применения в дерматологии их синтетических аналогов.

Рассмотрены и проанализированы данные литературы относительно этапов метаболизма ретиноидов в организме человека, механизмов их действия и свойств, обуславливающих их применение в различных медицинских областях. Обобщена информация по лечению дерматологических заболеваний природными ретиноидами и их синтетическими аналогами.

Приведена современная классификация ретиноидов, основанная на особенностях их химической структуры и функциональной активности, показана взаимосвязь этих характеристик и способов использования таких препаратов в дерматологии и косметологии.

Перспективы практического применения синтетических ретиноидов, представленных преимущественно полиароматическими соединениями, обусловлены их более высокой стабильностью и эффективностью, а также пониженным раздражающим действием благодаря избирательности к ядерным рецепторам.

Ключевые слова: ретиноиды, синтетические аналоги ретиноидов, механизмы биологической активности, ядерные рецепторы ретиноидов, дерматология.