

BIOTECHNICAL INFORMATION SYSTEMS FOR MONITORING OF CHEMICALS IN ENVIRONMENT: BIOPHYSICAL APPROACH

O. M. KLYUCHKO

Kavetsky Institute of Experimental Pathology, Oncology and Radiobiology
of the National Academy of Sciences of Ukraine, Kyiv

E-mail: kelenaxx@ukr.net

Received 29.09.2018

Revised 18.11.2018

Accepted 14.01.2019

The newest biotechnical systems for environment ecological monitoring based on the use of modern information and computer technologies and existing databases of chemical substances have been analyzed. In particular, there were observed such modern biophysical research methods as imitation and program modeling, based on the author results obtained in the experiments with registration of chemo-sensitive transmembrane electric currents in neurons in voltage clamp mode, use of neuronal fluorescent markers and accounting of organisms-bioindicators. The developed systems and methods allow revealing and identification of substances hazardous to living organisms and to make conclusions about their possible biological effects. The functioning of biotechnical information systems for environmental monitoring was analyzed in a wide time ranges, using modern databases, expert subsystems and interfaces capable to identify different types of chemicals. It is shown that for such systematic environmental monitoring it is possible to study and predict the effects of substances influences for a long time from the first moments of their exposure to individual cells of organism to months and years after exposure to the whole organism.

Key words: biotechnical information monitoring system, environmental pollution, bioindicators, databases.

Anthropogenic influence in nature is one of the most important problems of contemporary world. Ecological problems linked with environment pollution by chemical substances, hazardous for living organisms, are also important for all contemporary countries. One component of such antropogenic influence is technogenic chemical pollution in industrial regions. It appeared also as a result of accidents, disasters, contemporary military situations on the East of Ukraine, and etc. [1]. People have to direct constant efforts for revealing of such chemical pollution, for studying of its

influence on living organisms and for finding of the ways for such pollutants neutralizing or elimination.

For today, solutions to environmental challenges were aided by an arsenal of information and knowledge systems that were unavailable for most of the last 30 years [2]. However after a while biotechnological methods become used more and more for this purpose. Considering that knowledge about the causes of environmental ills had grown, the number of options arise on how to handle them as well as the development of collaborations and partnerships aimed

at harnessing the growing incentive-based approaches to environmental protection. As additional information technologies and knowledge management techniques evolved, environmental considerations will join other areas of strategic importance to industry. Information technologies become unique not just because of their growing use in decision-making and knowledge management systems, important as that is. Their use had also yielded significant improvements in the efficiency of energy and materials use, minimization of environment pollution by harmful organic substances [2]. Advances in information technology are likely to continue the opportunities providing for the development of improved and new versions of information systems in complex with biotechnological, analytical and other methods and their organization for ecological control [1]. For revealing, studying and neutralizing of pollutants a lot of different technical means, monitoring systems (MS), information systems (IS), and other samples of information and computer technologies (ICT) were invented and constructed during human industrial activity [1–14]. On the other hand people need more and more perfect solutions for these tasks due to appearance of the new ecological challenges as consequences of military actions at the territory of Ukraine today, technogenic disasters like Chernobyl one, other disasters at enterprises of chemical, oil and gas industry, like spread extensive fire of oil tankers in Kyiv region, Ukraine, in June 2015 with massive release of organic matter — pollutants.

Biological information systems (IS) suitable for such purposes, were designed either for academic purposes — to maximize the accumulation of information about the groups of living organisms or for the needs of economy, in particular for biotechnology, for monitoring of polluted areas in industrial centers, and etc. [1–15]. In our previous publications there were written about some mathematic methods used for IS we have constructed for monitoring purposes, about it different parts (databases, expert system, etc.) and other linked solutions [1, 3–12]. The present article unites and summarizes this great volume of published results. Mathematic methods as well as models that we described in our previous articles and published by other authors may be used for ISs functioning or to be simulated in result of their functioning [10–81]. A spectrum of mathematic methods were used for the newest

biomedical ISs elaboration [1, 11, 75, 77–80, 82–146]. The databases content described in this article was obtained usually from the results of biological and medical observations and experiments [10, 12–17, 24–44, 47–49, 61, 68, 71–74, 82–90, 94, 104, 106, 109, 111–113, 125–202]. All such technical information systems (tIS) are electronic databases (DB) distributed in networks today [1–11, 25–69, 90–109, 112–120, 159]. Present work was done after the analysis of more than 300 current publications in fields of biotechnology, other branches of biology and technology, including articles with original authors' works. The newest parts of authors work were defended by patents [172–182]. Prof. Zoya F. Klyuchko and Dr. Elena M. Klyuchko have studied such influences on organisms-bioindicators *Noctuidae (Lepidoptera)*, and a part of our works under the DBs and ISs construction we did with this biological material [1, 9, 42, 135, 136, 139, 140, 144, 156, 157, 159].

Brief review of some models of technical systems for environmental monitoring. Brief review of some models of technical systems for monitoring of environment using biotechnical means and some biophysical methods for the investigation is suggested below in this sub-chapter. Among great number of prototypes there are technical and laboratory systems, activities of which were directed on environment protection. We picked up them because they have some similar characteristics with our ones in our developed system for environmental monitoring.

1. The authors Nemtsov V. I. and Nemtsov A. V. had suggested a technical network system for monitoring of the state of environment [191]. According to the suggested method they took the probes in environment for further biophysical and analytical studyings. Such a technical network analytical system for the complex analysis and sampling of biophysical aerosols contained an electron microscope, a television microscope, made on the basis of a biological microscope with a fiber optic illuminator of side illumination of large fields of the subject plane for determining the particle size distribution and specific gravity of the particles in the sample. The analytical system had electronic scales and a multichannel sampler with a vertical suction channel. The latter were coupled with a variety of trapping elements with sampler substrate, filter, nutrient media,

and heat-resistant cassette for substrates, impacted and tipped for isokinetic selection. The tips had rotary adapters and were mounted on impactors. Substrates for microbiological analysis were made with recesses and with flat covers, transparent for light and electronic streams of probe radiation. Nutrient medium was enclosed in recesses. Substrates for deposition of physico-chemical aerosols were made in the form of covers similar to that of substrates for microbiological analysis. The method allowed to carry out complex analysis and sampling of biophysical aerosols. The invention increased the study of the nature of mineralogical, physical, bacterial and viral aerosols, allowed also to take measures for environment protection.

2. Another system for monitoring environment based on laboratory studying was described in [192]. It included fixed and mobile monitoring sites equipped with measuring instrumentations. Various environmental parameters were registered and subjected to analysis. More specifically, hydrophysical field signals were registered, the chemiluminescence, chromatographic, ion-selective, spectral and radiometric analysis was performed. Besides, bed acoustic impedance was registered, molecular spin interactions of seawater protons were detected, artifacts resulting from the magnetohydrodynamic, bioelectric and concentration effect were detected, synthetic surfactant content in the aquatic environment, chlorophyll concentrations, microorganisms, phytoplankton, zooplankton was determined. The collected data was further transferred to the archivers and modeling was performed. In the course of modeling the industrial facility environment and infrastructure were divided into a number of areas and a material balance model and a forecast model were created for each of them. For the purposes of the method implementation a system comprising a water withdrawal line equipped with hydrophysical field sensors, a filtering plant for chlorophyll concentration, a filtering plant with a Seitz funnel for microorganisms sampling, a Nageotte chamber for counting the phytoplankton content, a Bogorov Counting Chamber for enumerating zooplankton, a centrifugal apparatus for determining chlorophyll content, a geophone, spectral sensor of proton spin echo were proposed. Furthermore, the proposed system comprised the devices for

chemiluminescence, chromatographic, ion-selective, spectral and radiometric analysis, a radiation spectrometer, an atomic absorption spectrophotometer, an X-ray fluorometric analyser, TV sensors, infrared sensors, heat sensors, a metrological module, a sidescan sonar, multiple-beam echo sounder, water quality evaluator by TropoSample parameters and bed deposits characteristics, a lidar (a light radar), a penetrometer, methane and hydrogen detection sensors.

3. Other investigators [193] developed an enough perfect method to trace changes in characteristics of biological objects (in organisms-bioindicators) using technical system with "biosensor" for receptors' antagonists. Their invention related to a method for detection of receptor antagonists comprising the following steps: (I) a sample containing the receptor antagonist fractionated by use of a liquid-based separation means, preferably capillary electrophoresis, (II) a fraction containing the receptor antagonist or modulator that fed directly to a biosensor, which was activated by an appropriate receptor agonist and, as a result of this activation, generated a measurable response. The said agonist being fed to the biosensor through the liquid-based separation means together with the antagonist or modulator. The said activation of the biosensor being pulsed by delivery of the receptor agonist to the biosensor for short period of time. The said periods being separated by other periods when no agonist was delivered to the biosensor. And (III) the change of the response resulting from deactivation of the receptor agonist-activated biosensor by the receptor antagonist or modulator was measured preferably by means of a patch clamp electrode. It was further possible to resensitize the biosensor desensitized as above by use of pulsed superfusion of the biosensor. This invention also related to an apparatus usable for practicing the above mentioned method.

Another patent provided a highly specific modern way of studying changes in biophysical characteristics in bioindicator objects, including responses to external influences using optically active markers [194]. The invention provided polynucleotides and methods for expressing light-activated proteins in animal cells and altering an action potential of the cells by optical stimulation. The invention also provided animal cells and non-human animals comprising cells expressing the light-activated proteins.

The prototype system at the cellular level allowed the following mechanisms to be investigated and used: a) a delivery device comprising a polynucleotide that comprises a nucleotide sequence encoding a light-activated polypeptide, wherein the light-activated polypeptide comprises, from N-terminus to C-terminus; i) a core amino acid sequence that is at least 95% identical to the sequence shown in SEQ ID NO; 3, SEQ ID NO; 1, SEQ ID NO; 2, or SEQ ID NO; 4; ii) an endoplasmic reticulum (ER) export signal; and iii) a membrane trafficking signal; b) a light source; and c) a control device that controls generation of light by the light source.

Ideas about monitoring in few time intervals and about selection for studying of groups of influencing chemical substances. Pollution of environment with chemical substances in industrial and other regions is widespread today. The influence of such substances is long-term usually and starts often from the moment of pollution. That is why we see as crucially important to study the influence of polluted substances at once after the moment of pollution and during long months and even years (if possible) on living organisms and their populations; and this is one stream of our interests in the present study.

The second stream of our interests is the object of studying. There are some effects of organic substances represented by phenol and indole derivatives. Although the wide spectrum of chemical substances was known as components of chemical pollution, the influences on organisms of hazardous and dangerous organic chemicals are less studied because of different reasons. Among them there are their non-stable structures in nature, "masking" of their effects by great number other organic substances in living organisms and so on [190]. From the other side, these chemicals are enough important from the point of view of their "chameleon" effects: hydrophobic circles are able to inquiry cell membranes easily, and their radicals may have hydrophylic nature and to be located outside of the surface cell membranes. Such "anchored" structures are able to occur great effects in living organisms; up to the lethal results sometimes. These substances form the large group of environmental pollutants; but among them also there are powerful toxins from living nature, like Arthropods' or Insects' toxins.

The author of this article studied influence of different organic chemicals, like phenol —

and indole — derivatives with polyamine radicals of different length and complexity (PID-PR) during couple of the years [172–183]. Further, the author developed some devices and methods for monitoring the effects of such substances. In general, PID-PR substances play different roles in nature. On the one part, they are incorporated into living organisms by themselves. On the other part, substances with similar structure are components of out fluxes of industrial activity, accidents or disasters that influence hazardously on biological organisms of different hierarchical levels and especially on neurons of organisms [190]. Among ecological toxins there are a lot of substances with such chemical structure (below we call them also ecotoxins).

Novel scheme and technical system for monitoring of some chemicals influence in nature. In the article it is suggested a novel monitoring scheme that included different components: organizational, technical, biotechnical, IS-component, ICT-component, novel invented methods, and etc. (Fig. 1). For this system, its main parts and developed methods of monitoring were defended by patents [173–176, 178, 182, 183].

Monitoring with the use of this developed system could be carried out in three time intervals after beginning of substance action:

- 1: 0.5 ms — few minutes;
- 2: 10 min — 4 few hours;
- 3: during few months and years.

Respectively, there were elaborated different methods and equipment and used technical means for different time intervals. Correlation between them was depicted on Fig. 1. Detailed information about each time interval of monitoring is suggested below.

Purpose and tasks of the work. The work was aimed at a biotechnical information system developing for monitoring in environment the chemical organic substances harmful for living objects with relative methods for diagnostics of such substances in nature for studying of their effects on living organisms and their populations with further making of necessary recommendations for nature protection in different regions.

In the furtherance of this goal it was necessary to solve the following tasks:

1. To analyze contemporary prototypes of different information system for monitoring in environment.

2. To develop new contemporary experimental methodics connected with stated tasks solutions on the base of contemporary biophysical methods.

3. To develop methods for perfection of chemosensitive transmembrane electric currents (CTE — currents) in voltave-clamp conditions by the decrease of the noises' levels during electrophysiological experiments in voltave-clamp conditions; and by perfection of electrical signal revealing on the background of noises.

4. To study the influence of chemical organic substances, harmful for living objects, on chemosensitive transmembrane electric currents (CTE — currents) in voltave-clamp conditions. Mainly to study effects of derivatives of phenol and indole linked with polyamines of different length and complexity.

5. To study the changes in living neurons' optical properties by marking them by fluorochromes using method of retrograd axonal transport.

6. To make mathematical processing of obtained results and to develop relative mathematic and program models for effects studied in (3–5). For different segments of this biotechnical system the software development C++, C#, Java were used.

7. To conduct long-term monitoring of bioindicators populations (*Noctuidae*, *Lepidoptera*) in different regions and conditions with further processing of the obtained results (also in case of environment pollution by studied organic substances).

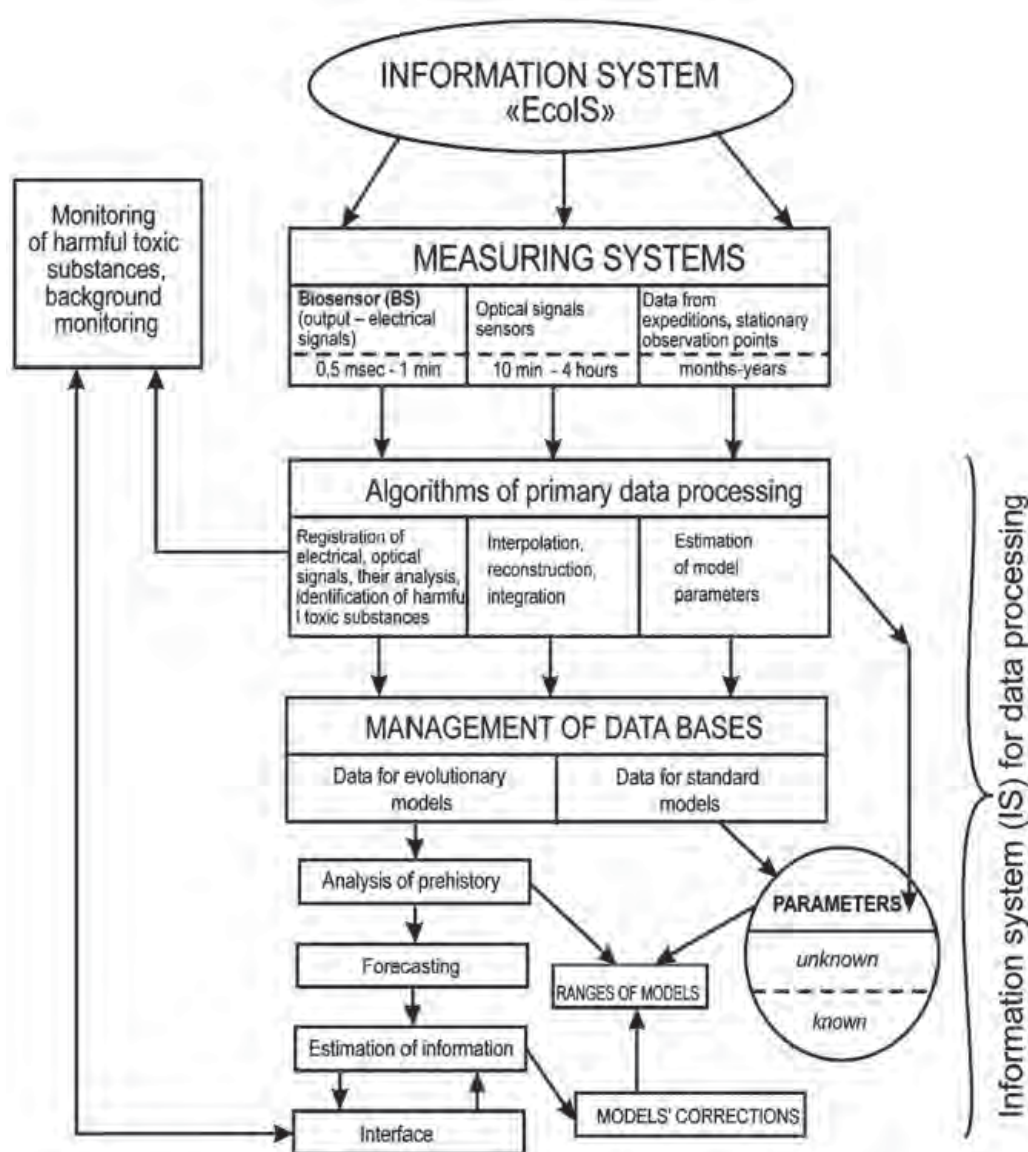

Fig. 1. Information system for monitoring the influence of some chemical substances on living organisms and their populations "EcoIS" [1, 173–176]

To develop the new methods of ecological monitoring of different ecosystems state with further analysis of the obtained data and with the recommendations for some regions of Ukraine (Carpathian Mountains, Middle Podniprovia, Donbas — “Striltsivskiyi Steppe” Preserve in Luhansk region) and Russia (Caucasus Mountains, Kabardino-Balkar Republic).

8. On the base of (1–7) to develop new contemporary complex biotechnical system for obtaining and processing the data concerning environment with databases (DB), automated electronic work places (EWP) with interfaces, in which there were united novel measuring devices, biodetectors and bioanalyzers, computer means, algorithms for data processing and methods for monitoring the bioorganisms (bioindicators) and ecosystems state. This biotechnical system was named as “Ecological Information System” — “EcoIS” [176].

So, “EcoIS” was developed to study and to monitor the influence of harmful substances (like some phenol — and indole — derivatives with polyamine radicals of different length and complexity — PID-PR) on living organisms in few time intervals. From the one side, it gives a possibility to study their mechanisms of influences; from the other side — to trace the influence of PID-PR on organisms during long periods of time (human or non-human organisms). And all of these in complex give more possibilities to prevent and to neutralize harmful PID-PR (and other) more long-term effects on humans.

Three time intervals were studied, and these time-intervals may be grounded reasonably by biological phenomena in the studied living organisms and the instrumental possibilities (experimental, monitoring, data mining, etc.) So, the time intervals selecting was due to the following:

1) (0.5 ms — few minutes) — in this time interval the changes in neuronal membrane electrical responses under PID-PR influences on CTE — currents have happened; they might be registered in voltage-clamp conditions, patch-clamp, other methods of this pool.

2) (10 min — 4 few hours) — in this time interval biochemical processes in neurons “in response” to chemicals’ influences on neuron have happened. They might be revealed by fluorescent markers (the optical studyings were carried out by UV-microscopy method using the “LUMAM” fluorescent microscope produced by “Carl Zeiss” Company in Jena, Germany).

3) (during few months and years) — in this time interval the monitoring of changes in *Noctuidae* (*Lepidoptera*) organisms and

populations was provided (collection of insects was carried out using light traps, field collections, other linked methods).

In such a way it was possible to register different aspects of the studied substances influences: (1) — the quickest electric processes in response to chemicals’ influences; (2) — more slow biochemical processes in response; (3) very slow changes in the whole organisms and consequences of chemicals’ influences on insects populations.

Brief information concerning the developed biotechnical system for ecomonitoring. The basis for biotechnical system for ecomonitoring elaboration was aimed to develop a method for the use of a network computer biotechnical monitoring system for deep large-scale study of the effect of a large number of types of chemicals on organisms-bioindicators in a wide range of time: from the moment when the chemical substance started to influence to the long-term consequences in a few years (including the effects of pollutants of the environment).

For this problem solution the biotechnical information system were developed called BTSM-3 with databases (DB), in which the subsystems of three types were united. BTSM-3 is a system that unites technical means and methods for monitoring in three time intervals. The system “EcoIS” was based on BTSM-3 but included also other subsystems, services and possibilities as follows:

1. The first subsystem contained at least one sensor (biotechnical system — BTS) with biological fragment (BF — cell, cell membrane, etc.). This sensor was included for the registration of transmembrane electric currents in single cells that might be influenced by different chemical substances. Such sensor might be a part of the whole sensory group with relative methods. It might be called a “sensor” or “detector”. Time intervals of registration by the subsystem 2 and subsystem 1 were not always overlapped (Figs. 2–4).

2. The second subsystem was another sensory group — detecting group. It was developed, organized and supplemented with relative methods and serves to perform the optical registration of changes in the internal environment of cells marked *in vivo* by the fluorochromes, the dyes-markers (VDM), such optical changes of the cells’ internal environment appeared in response to the action of some chemicals applied to the cells (Fig. 5).

3. The third subsystem was developed and organized to account the biological organisms-indicators (bioindicators) with the purpose to study the results of both qualitative and

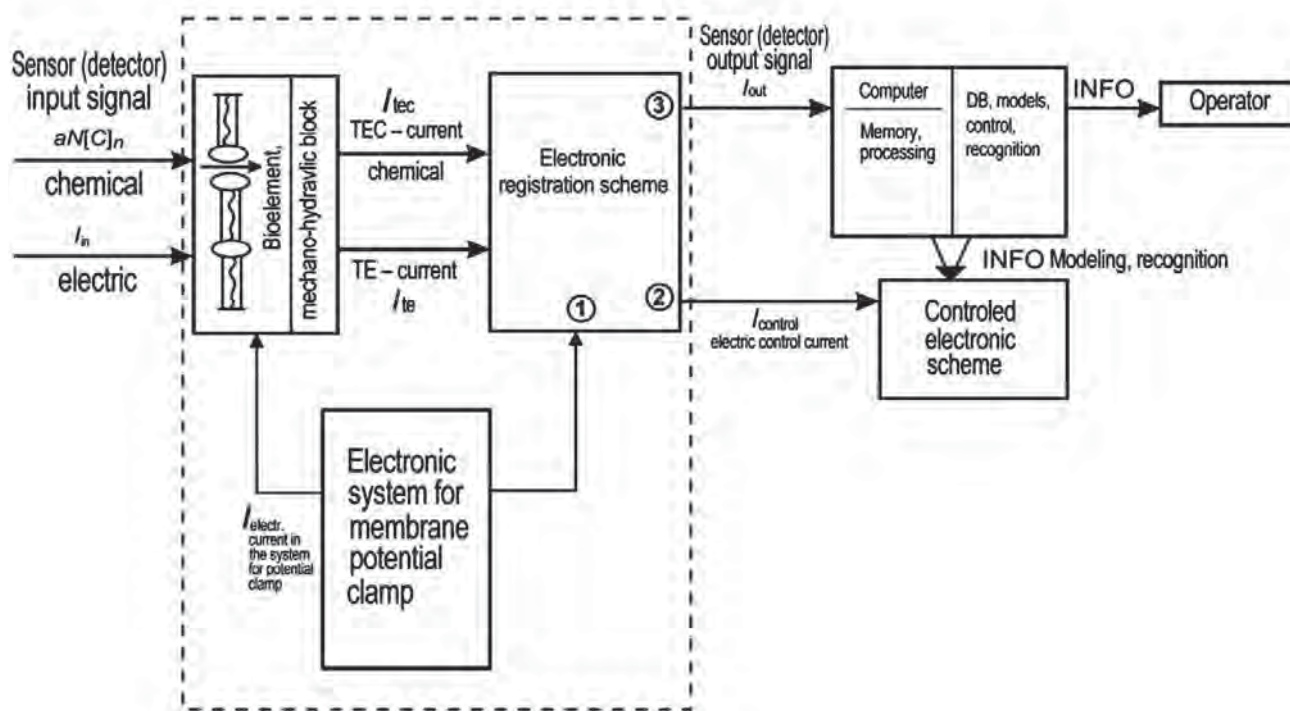

Fig. 2. Block diagram of the technical sensor system in the “EcoIS” (BTSM-3). This complex may be an element in the block “Measuring system” (Fig. 1):
 at the input of the system information comes in the form of electrical or chemical signals,
 at output — in form of electrical signals

quantitative composition of bioindicators' populations (Fig. 6).

So, we proposed to use the developed biotechnical system BTSM-3 for the large-scale monitoring, using the deep study of the effects of chemicals influence on the organism in different time intervals, from the moment of the start of their action on the organism. BTSM-3 was constructed as a biotechnical information system on the basis of relevant databases with direct and/or remote access that contain a number of subsystems and sensory groups.

In BTSM-3 there was in-built subsystem-sensor BTS with BF (there may be one or more such sensors, or detectors) characterized by the unity of three parts: mechanical-hydraulic part with BF, electric part and computer part. The last one allowed the registration of new received data, and also makes it possible to record in memory of the computer (PC). The obtained results were possible to record in DB (in local and/or network databases), to visualize them, to perform processing, analysis and data extraction, to make the data transmission using network technologies about the action of various chemicals. The registration process of the BTS occurs in the

following sequence: the chemical substances were applied to BFs that were possible to substitute one by another. After respective agonists application there were possible to register the changes of electric transmembrana signals from BF using voltage-clamp, patch-clamp, microelectrodes' techniques or other methods of these types. The effects of applied in BF substances were measurable and able to be recorded.

The developed method and relative biotechnical system BTSM-3 differs from the other because it unites three subsystems that were built into the BTSM-3 for the monitoring of the increased number of chemical substances and for the expansion of the monitoring intervals after the time of start of the substances action.

For the use in sensor group, BF had to undergo preliminary processing according to specially developed procedures [172, 177] including enzyme treatment by proteases of *Aspergillus oryzae* and/or others substances in solutions with a selected composition, which are in contact with the gas environments of special composition, temperature and time modes of treatment. The substances acting on the BF could be obtained using various

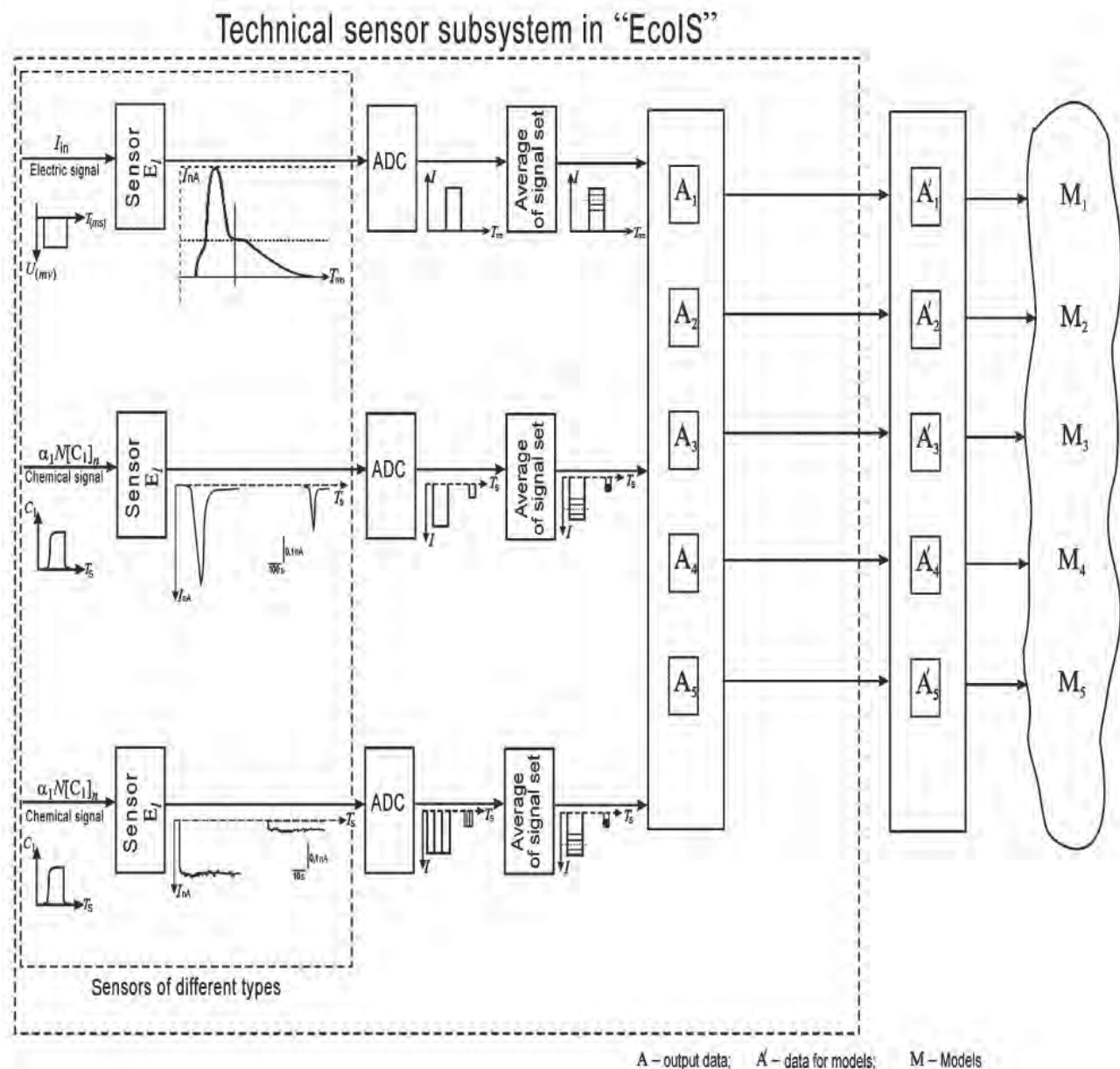

Fig. 3. From the electrical signals to the mathematical models: at the input of the BTS system with BF the information comes in the form of electrical or chemical signals, at output — in form of electrical signals. M — different mathematic models from the developed models family

chemical and biochemical methods. For the substances application a specially developed concentration-clamp method might be used. It was important as well to improve the registration of the output electric signal, improving its allocation to the background of the noise and significantly reducing the noises by themselves. Also the BF could be replaced depending on the processing of molecules of their surfaces, the type of chemicals that were analyzed. BF acts as the primary link in the sensor — biodetector and/or bioanalyzer of acted substances (including environmental

pollutants). The input of computers in the BTSM-3 network received the information from the databases, the data as electrical and optical signals from detector subsystems, and data of bio-indicators' organisms counting.

Let's describe briefly some peculiarities — instrumental, methodics, etc. — for each time period of monitoring in details, as well as some obtained results.

Peculiarities of monitoring at the first time interval — at once after the influence of chemical substances. The first time interval of monitoring is between 0.5 ms — few minutes

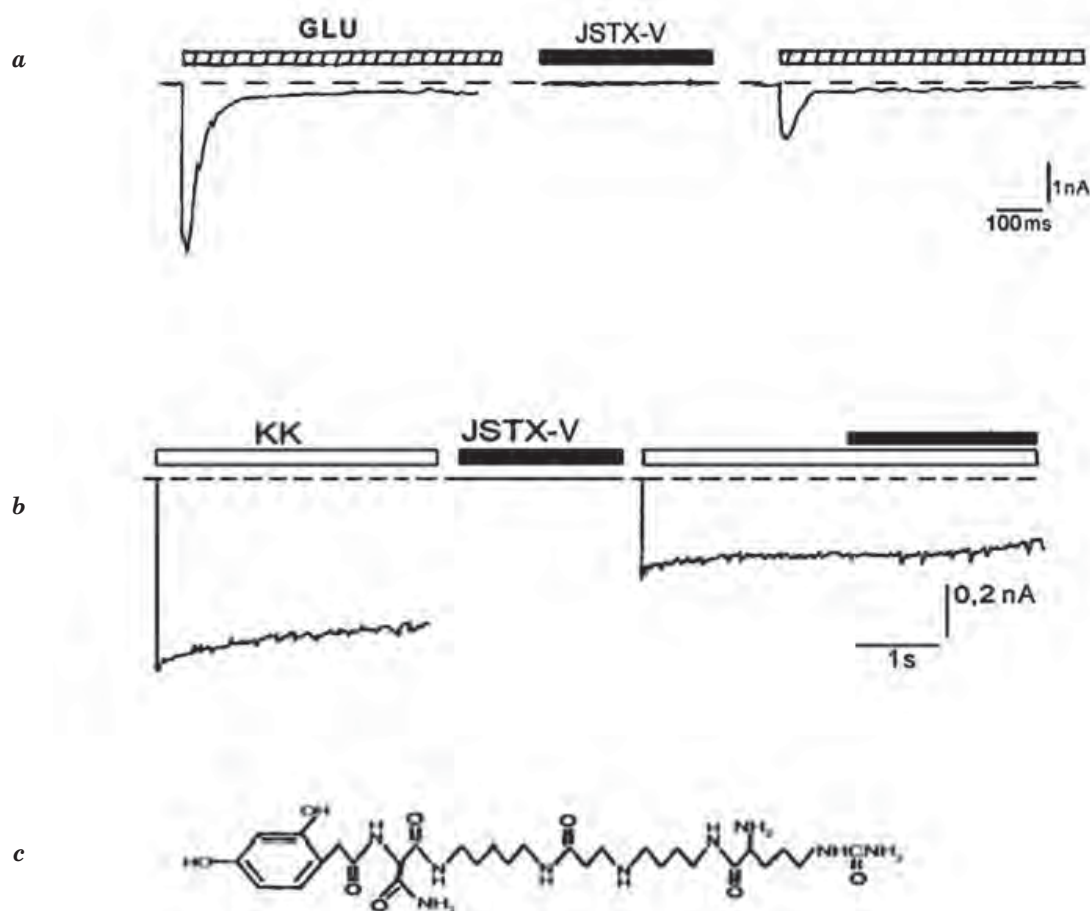

Fig. 4. Electrical signals at the output of the BTS. Substance JSTX-V blocks chemo-activated transmembrane electrical currents in membrane of rat hippocampal pyramidal neuron:

a — influence on glutamate-activated (Glu) currents; *b* — influence on kainat-activated (KK) currents. After the registration of the control responses to Glu and KK, the membrane was maintained in Ringer solution with JSTX-V ($2.5 \cdot 10^{-4}$ units/ μ l) during 3 min. In this experiment the amplitudes of chemo-activated currents decreased after the JSTX-V influence. Experiment with JSTX-V re-application in the same concentration ($2.5 \cdot 10^{-4}$ units/ μ l) on the background of KK is shown on (*b*). Concentrations of Glu and KK were 1 mmol/l (*c*). Chemical structure of JSTX-3 — active compound of JSTX-V and antagonist of chemo-activated electrical currents V hold — 100 mV [164, 173–178]

after the influence of chemical substances on the cells' surfaces. The most fast processes of electrical nature is possible to record in this time interval. There are changes in neuronal chemosensitive transmembrana electrical currents (CTE-currents) under the influences of different chemical substances (as well as PID-PR influences). CTE-currents' registrations there were possible to do using microelectrode techniques, in voltage-clamp conditions, patch-clamp, and others.

The devices, equipment and methods used there (both standard and newly developed) were elaborated and used in complex. This complex with studied neuronal membrane or

membrane of other type of cels (let's call them "biological fragment" — BF) served, in fact, as "biodetector" and "bioanalyzer" for chemicals, applied to BF. To realize this step there were elaborated the new methods: biological cells dissociation, their cultivation, testing of PID-PR influence on trans-membrane currents in cells, some PID-PR diagnostics [172–183]. For these the results of many-year experimental author investigations of electrical signals and processes in natural membranes of neurons (MN) were described. Also there were described experimental data about electrical chemo-activated trans-membrane currents with molecular structures in MN gated them, as

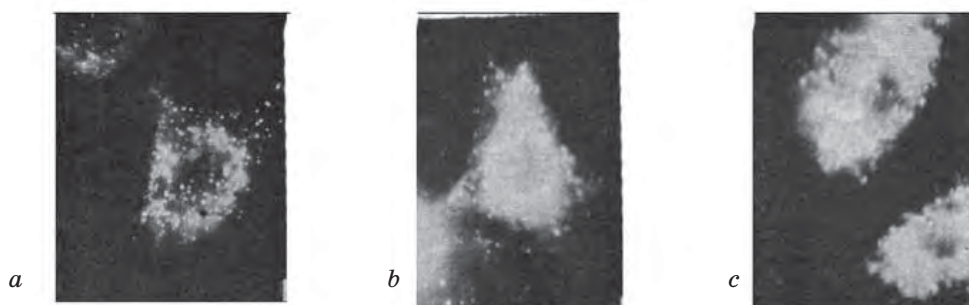

Fig. 5. Strengthening the brightness of molecular complexes of primulin-protein in neurons after the agonists action:

fluorescent granules contained complexes of primulin with proteins of the cytoplasm: *a* — control. Weak fluorescence at lack of action of agonists; *b* — enhanced fluorescence of neurons after 20 minutes from the start of action of excitatory agonists (*b* — GABA; *c* — acetylcholine) [1, 17]

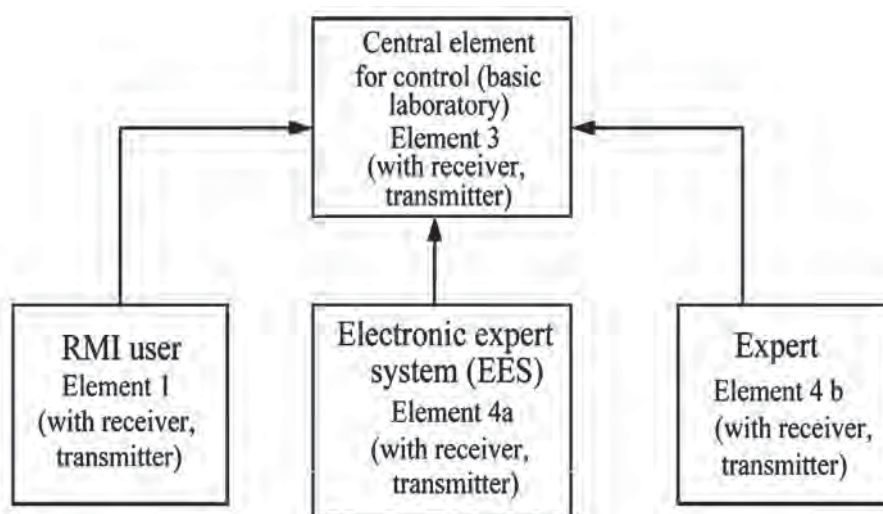

Fig. 6. Fragment of structural scheme of IS for tracing of insects' population states

well as methods of such current characteristics control by some organic molecules, like PID-PR. The methods of enhancing of MN chemo-activated currents amplitudes registered in experiments and their perfected revealing among noises were elaborated and patented [172, 177]. Some possible ways of insertion of this complex of devices for electrophysiological experiment into the technical IS were suggested.

The obtained data were important for elaboration of the newest biosensors — electronic elements of technical systems, IS for eco-monitoring, new technical expert systems for detection and diagnosis of ecotoxins in the environment. The appropriate methods and means of the parameters measuring of electrical information signals from neurons were considered. Namely, the experiment examples with voltage-clamp and concentration-clamp on MN were done as well as activation under these conditions of

CTE-currents — glutamate-activated (Glu) and kainat-activated (KK-). As it is shown in the work, this control could be achieved, for example, by acting on the MN of the mammal central nervous system by specific toxins — blockers (BTx) of Glu — and KK-activated channel-receptor complexes (or antagonists of Glu — and KK-activated channel-receptor complexes) with the purpose to block CTE-currents. At the same time, under the conditions of the experiments, there were registered the interaction between three types of molecular structures: molecular channel-receptor complex (CRC), agonist molecules A (Glu, KK), and the molecules of CTE-currents' antagonists (BTx).

On Fig. 3 one can see the schematic description of all complex work done in the developed system, from primary registration of bioelectrical signals in the experiment under the influence of different chemical substances on neuronal membranes (left) — to computer

processing of such signals (values averaging and further processing; A — at middle) — and than to the development of mathematical and program models (M — at right).

The main experimental results were described and analyzed in [16, 17, 26, 143, 153, 163, 164, 173-183], the brief list is below.

- The method of amplification of 11.8 times the amplitudes of CTE-currents (electrical signals) at the output of the sensor and the improvement of detection of them at the background of noise during registration in experiments was developed, which is important both for the registration of CTE-currents; the patent was obtained on this method [172, 177];

- algorithms for preparation of BF element of sensor — neuronal membranes (MN) from hippocampus of the rat central nervous system and algorithms for carrying out the experiments, data on the registered physical and chemical properties of experimental objects;

- the experiment results on the registration of CTE-currents — signals at the output of the sensor group, which represent a series of digitized records of CTE-currents in response to the activation of CRC molecule by agonists (A) with known chemical structure of the molecules;

- there were obtained the data on the control of the output signals of BTS by blocking or modifying of the registered CTE-currents after the influence of six different specific toxin (JSTX-V, JSTX-3, AR-V, AR, ARN-1, ARN-2) on the CRC. The molecules chemical structure of four investigated antagonists was established, the other two antagonists were the mixture of the substances.

Data from the series of studied effects of various types of antagonists were summarized in the DB and relative tables. The effects of all studied antagonists' influences on CTE-currents were similar, but they were characterized also by number of distinct features, which allowed the development of certain approaches for the creation of new methods of qualitative and quantitative analysis of organic substances with toxic effects in the environment.

Further there were done:

- mathematical processing and analysis of the experiments results described above on the registration of CTE-currents at the output of the BTS;

- generalizations and conclusions regarding the correlation of characteristics of the blocking effect of CTE-currents influenced by the toxins with differences in chemical

structure, in particular, with different lengths and structure of polyamine;

- elaboration of mathematical models of registered effects under the influence of specific antagonists of Glu — and KK-currents (3 phases of interaction between molecules were considered);

- material on the application of mathematical cluster methods to distinguish similar features in registered effects.

In order to develop fundamentally new methods for qualitative and quantitative analysis of organic pollutants in the environment, the dose-effect dependences for coupling of studied substances were investigated in the experiments. The values of Kd for all possible cases for the action of all antagonists were calculated (for JSTX-3 as well as AR and other antagonists from *Araneidae* venom). The dose-effect dependencies were single-bonded isoterms. They demonstrated the lack of co-operability. It was shown that the magnitude of the amplitudes of currents under the action of AR decreased by 2.7 times, but the nature of dose-effect dependence had not been changed. Consequently, AR did not compete with KK for binding sites on the receptor according to the results of our experiments.

The obtained dependences were proposed to put in base of new methods of detection, quantitative and qualitative analysis of the presence in environment some organic substances-pollutants. Thus, in the samples from industrial territories contaminated with organic harmful, toxic substances [190], on the basis of these dependencies it becomes possible to detect and pre-diagnose the approximate type of chemical pollutant. The regularities of the action of phenol and indole derivatives with polyamine radicals of different lengths and complexity on the CTE-currents were studied [16, 17, 26, 143, 153, 163, 164, 173-183]. The conclusions about the correlation between the chemical structure of various chemical substances (including pollutants) with their physiological effect on electric currents both on the molecular level and on the level of organisms were made.

Peculiarities of monitoring at the second time interval (10 min — few hours) after the influence of chemical substances. In this time interval it was possible to register biochemical processes in neurons “in response”, after the influence of chemical substances on the cells. These effects were revealed by using the method of neurons retrograde marking by fluorescent markers *in vivo*. Optical studyings

were done using UV-microscopy — “LUMAM” (fluorescent microscope from “Carl Zeiss”, Iena, Germany) [1, 17]. For this step realization there were developed the method of neuron state registration using some fluorescent markers that actually gave possibility to visualize the coupling between electrical and chemical changes in neurons with their optical characteristics. Results of these experiments enables to visualize the changes in electrical characteristics of the system as sets of images with their future ordering in databases (DB). Fluorochromes primulin and bis-benzimide were used for these experiments. The signal was received when molecules of agonist (A) were applied to MN at concentrations of approximately 10^{-4} mol/l. Before this, the molecules of fluorescent marker primulin were introduced inside the neurons using retrograde axon transport; and they formed complexes with proteins in cell soma. The experiments technique at all stages were described [1, 17], ending with observations on changes of optical characteristics of neurons in thin sections of rat brain with the help of luminescent microscope in the mode of incident light (Fig. 5).

From the experiments shown at Fig. 5 it is possible to see that before the action of the exciting signal (*a*) the brightness of the fluorescent marker primulin was much weaker than after acting on the MN of the agonists (*b*, *c*). After the action of the agonist molecules, the number of light granules in the cytoplasm of the neurons increases tremendously, the brightness of each granule increased (from the photo it is seen that the size of each granule increased), their number increased in the zone of the nucleus with the formation of the ring. Similarly, the changes in the characteristics of the fluorescing complexes caused other agonists as well, we had studied 5 agonists [1, 17]. In their ability to cause the effect of fluorescence change, the agonists could be arranged in the following sequence:

adrenaline > acetylcholin e> GABA >
> glycine > serine.

In case of application of the method of neurons' marking using retrograde axon transport, the processes of neurons were usually well visible: their trajectories were marked with luminous granules of primulin-proteins. Under the action of agonists on the neurons, the “marked” parts of the processes were significantly lengthened, exceeding two or three diameters of the neurons.

Mathematic and program modeling of different phases of electrical impulses

development in MN in framework of studied systems were done. There also were developed some mathematical and program models of systems with the use of studied effects, the principles of information coding by such systems were suggested [1, 25, 72].

Monitoring at the third time interval — long-term monitoring during few months and years. This long-term monitoring was realized by studying of changes in biological organisms. For such studyings we selected as organisms-bioindicators insects *Noctuidae* (*Lepidoptera*) — single insects, species and their populations. Insects were collected using light traps, field collections were done as well.

As a result of the works for the development of monitoring system in the third time interval — long-term monitoring of environment — the original IS with DB of images were developed and suggested for use in ecological scientific and academic practice, for environment protection. Detailed analysis and studying of peculiarities of biological objects and necessity to use of mathematic and other methods that were not used before became the basis for the DB development [166–170]. The series of these works were continued by the elaboration of some IS with DB, including DB of images, and electronic working places linked with DB for professionals of few specialties (ecologists, zoologists, and some others).

The complex of the works done concerning this time interval included practical development of electronic systems for monitoring of environment, for example, using monitoring of bioindicators (*Noctuidae*, *Lepidoptera*) in different regions of Ukraine and neighboring countries. As it was written above the biotechnical system developed for such purposes is called “EcoIS”, its fragment is suggested on (Fig. 6). Developed technical ISs with databases for *Noctuidae* (*Lepidoptera*) basing on the results of their study in the mountains of Elbrus region (Caucasus, Russia) during environmental eco-monitoring in extreme conditions was described as well [1, 9, 10, 174, 175, 176, 178]. It should be noted that the adaptation of bioorganisms in extreme conditions takes place according two strategies, and strategy of adaptation of insects differs from the strategy of adaptation of mammals.

The list of the works done in the framework of the third time interval includes the following materials [1, 9, 10, 174, 175, 176, 178]:

– problems of the network IS development with databases were discussed; there were

observed IS with databases of images, ISs with distributed databases;

– problems of designing the database for ecology, according to eco-monitoring results basing on the results of the study of bioorganisms in extreme conditions were observed and discussed;

– general overview of the methods of mathematics and computer modeling in the field of environment protection, other spheres of medicine and biology were done;

– algorithms of ecomonitoring of fauna of different ecosystems with the use of the possibilities of academic IS and networks with distributed bio-organism databases were presented;

– possibility of development of IS for eco-monitoring with databases of images have been demonstrated;

– the effectiveness of the newest methods of ecological monitoring of bioorganism populations on the basis of network IS with distributed databases was demonstrated including mathematical analysis of the data obtained in conditions of monitoring points distributed on the territory of the country;

– results of the work on the development of “EcoIS” system for eco-monitoring were obtained (Fig. 7). “EcoIS” is a “system of academic destination” [1, 7, 8]. Being electronic networking system with distributed *Noctuidae* (*Lepidoptera*) databases, “EcoIS” is

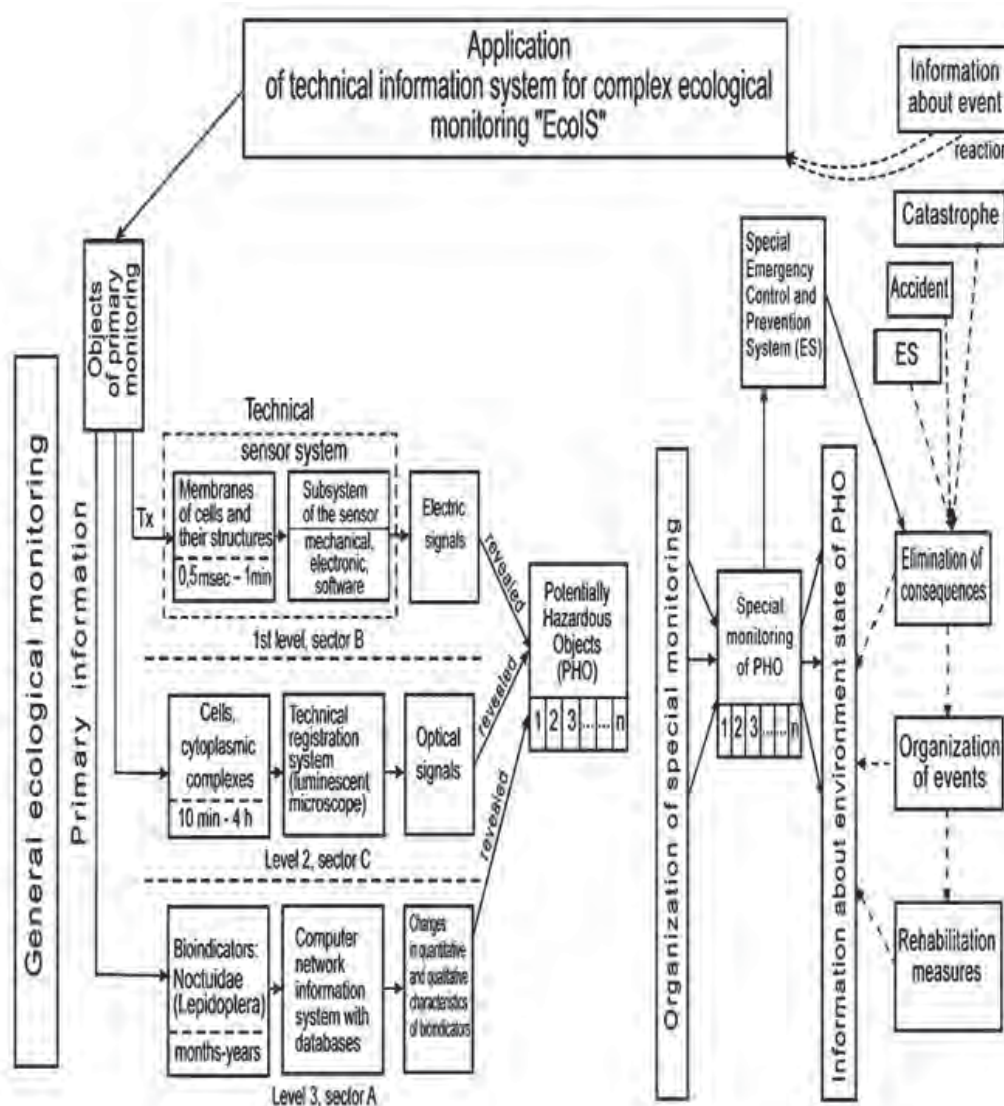

Fig. 7. Application of the technical system “EcoIS” for monitoring of bioobjects of different levels of the hierarchy:

the methods used in the various sectors of “EcoIS” allowed to receive qualitatively new information in comparison with the previous ones and to realise qualitatively new monitoring possibilities

possible to use for ecomonitoring in different regions of Ukraine;

- application of the developed methods and results of monitoring of bioindicators in the Striltsivskiyi Steppe Preserve (Luhansk region, Ukraine) and for comparative analysis of some bioindicators in the mountain regions of Carpathians (Ukraine) and Caucasus (Russia) were demonstrated;

- automatized electronic working places linked with DB for professionals of few specialties (ecologists, zoologists, and some others) were constructed. They became interfaces to “EcoIS”.

At the end of the description of the work done it is necessary to emphasize two positions.

I. Scientific novelties of the work done were as follows:

- for the first time it was proposed the technical system of environmental data collection and processing in which the biotechnical sensors (detectors) were connected with electrical signals with measuring devices, computer means; the system also combined algorithms of data processing and methods of eco-monitoring;

- for the first time there were developed the methods and biotechnical devices — sensors (detectors), which allow measuring the influence of toxic substances much more accurately (by several orders of magnitude) compared to current ones;

- for the first time a new type of methods for quantitative and qualitative analysis of organic substances (including pollutants) was invented as a method, which allows to recognize approximately the chemical structure of organic compounds in dependence to their influence on transmembrane electric currents, so in dependence to physiological effects they occurred. Some patents were obtained for these methods [179–183]. These works formed the scientific basis for the development of the new technical systems for such organic substances detection and analysis.

II. Practical values of the obtained results are as follows.

- A software and analytical system were developed for ecological monitoring «EcoIS», which enabled the conducting works on eco-monitoring on various objects of Ukraine (in the regions of industrial pollution, in areas with extreme conditions, where such monitoring was not possible due to lack of funds or difficult access to these locations, and etc.).

- The inverse problem of organic chemical substances determining, the presence of pollutant molecules in the nature by their effects on the CTE-currents were solved. The

theoretical dependence of the damaging effect of ecotoxins on their chemical structure was found. Such dependence might be the basis for the development of new technical expert systems for monitoring and analysis of some organic compounds in pollutants.

- There were elaborated the automatized electronic workplaces (ERM) and an improved analytical research complex for scientists of several specialties. Such ERM became interfaces for communication between human and “EcoIS” or other systems from this family.

- The described results in their different parts and at different years were implemented at the National Aviation University, the International Center for Astronomical and Medico-Ecological Studies (ICAMED) of the National Academy of Sciences of Ukraine in the Caucasus (Russia, the Kabardino-Balkaria Republic), at A. A. Bogomoletz Institute of Physiology and Kavetsky Institute of Experimental Pathology, Oncology and Radiobiology of the National Academy of Sciences of Ukraine, Uman State Pedagogical University named after P. Tychna. The obtained results were also used for monitoring of the bioorganisms of the Donbas — Striltsivskiyi Steppe Preserve (Ukraine), at Ukrainian Polissia, in the extreme conditions of Ukrainian Carpathians and the Elbrus region (Caucasus, Russia).

Thus, in process of the work described above there were obtained the following results, partially defended by patents [172–183, 195–199].

1. The scientific basis was developed and the newest technical system for eco-monitoring was developed. It used a new type of the sensor groups as a technical means for the state of the environment monitoring. Accompanying laboratory, experimental methods and appropriate researches were done. The sensor model as part of a technical system for the diagnosis and testing of ecotoxins was elaborated. The corresponding software was developed.

2. The numerical characteristics of interaction for all studied toxic substances were investigated, mathematical description of the processes of CTE-currents blocking by them were performed. The general laws of the damaging action of toxic substances were established. Due to the phenolic and/or indole fragments of the molecule of a toxic substance, it interacts with the hydrophobic components of the membranes. Due to the polyamine — it interacts with the glutamate receptor (Glu-R), providing the main mechanism of currents’ blocking. New methods of quantitative and qualitative analysis of studied toxic and harmful organic compounds in environment were proposed.

3. The method to amplify by 11.8 times the amplitudes of CTE-currents in neuron membranes (MN) was elaborated. It enabled to improve electric signals detection against noise backgrounds. Using the elaborated method, experimental recording of CTE-currents became more perfect. So, all further electrophysiological recordings became more perfect as well. These methods were patented [172–177].

4. The methods of optical registration of processes of neurons excitation at the molecular level of the action of 5 different agonists were elaborated and applied in the experiment. The method of retrograd dye axon transport was used for this.

5. Algorithms, mathematical and program approaches for elaboration of the databases (DBs) for the developed “EcoIS” system, ERM, others, taking into account the features of bioobjects were proposed.

6. ERM — automated electronic work places — were developed on the basis of the corresponding databases for use by scientists-biologists of several specialties (ecologists, neurotoxicologists, zoologists, etc.). They became interface to the system “EcoIS”. ERM were

elaborated on the basis of network technologies, their structure, functions. The developed ERMs are easy to use and quite satisfactorily meet the requirements of the relevant experts in experimental and theoretical data.

11. An example of a network technical information system based on distributed databases with information on bioindicators *Noctuidae (Lepidoptera)* (the system “EcoIS”) was developed for the purpose of its use for professional monitoring of bioorganisms. This system included DB with the results of ecomonitoring for some regions of Ukraine (Striltsivskyi Steppe Preserve (Luhansk region), Carpathian Mountains) and Russia (Prielbrusie). It is possible to use this system for monitoring with the aim of environmental protection. For this purpose it has to include also environmental monitoring equipment for the detection of polluting organic compounds, ecotoxins, to ensure environmental safety around industrial enterprises, including damaged as a result of accidents, man-caused and ecological disasters, in the areas of military actions, as well as accidents at chemical enterprises, other accident zones with industrial pollution.

REFERENCES

1. Klyuchko O. M. Information and computer technologies in biology and medicine. *Kyiv: NAU-druk*. 2008, 252 p. (In Ukrainian).
2. Allenby B. R., Compton W. D., Richards D. J. Information Systems and the Environment Overview and Perspectives. <https://www.nap.edu/read/6322/chapter/2>
3. Klyuchko O. M. Application of artificial neural networks method in biotechnology. *Biotechnol. acta*. 2017, 10 (4), 5–13. <https://doi.org/10.15407/biotech10.04.005>
4. Klyuchko O. M. Cluster analysis in biotechnology. *Biotechnol. acta*. 2017, 10 (5), 5–18. <https://doi.org/10.15407/biotech10.05.005>
5. Klyuchko O. M. Technologies of brain images processing. *Biotechnol. acta*. 2017, 10 (6), 5–17. <https://doi.org/10.15407/biotech10.05.005>
6. Klyuchko O. M., Onopchuk Yu. M. Some trends in mathematical modeling for biotechnology. *Biotechnol. acta*. 2018, 11 (1), 39–57. <https://doi.org/10.15407/biotech11.01.039>
7. Klyuchko O. M. Electronic information systems in biotechnology. *Biotechnol. acta*. 2018, 11 (2), 5–22. <https://doi.org/10.15407/biotech11.02.005>
8. Klyuchko O. M. Information computer technologies for biotechnology: electronic medical information systems. *Biotechnol. acta*. 2018, 11 (3), 5–26. <https://doi.org/10.15407/biotech11.03.005>
9. Klyuchko O. M., Klyuchko Z. F. Electronic databases for Arthropods: methods and applications. *Biotechnol. acta*. 2018, 11 (4), 28–49. <https://doi.org/10.15407/biotech11.04.028>
10. Klyuchko O. M., Klyuchko Z. F. Electronic information systems for monitoring of populations and migrations of insects. *Biotechnol. acta*. 2018, 11 (5), 5–25. <https://doi.org/10.15407/biotech11.05.005>
11. Klyuchko O. M. Expert systems for biology and medicine. *Biotechnol. acta*. 2018, 11 (6), 5–28. <https://doi.org/10.15407/biotech11.06.005>
12. Klyuchko O. M. On the mathematical methods in biology and medicine. *Biotechnol. acta*. 2017, 10 (3), 31–40. <https://doi.org/10.15407/biotech10.03.031>
13. Roland Eils. Expert system for classification and prediction of genetic diseases. *Patent US, JP, CA, WO2002047007A3*. Priority date: 2000-12-07. WO Application 2002-12-12. <https://patents.google.com/patent/WO2002047007A2>
14. Prasad S. Kodukula, Charles R. Stack. Water treatment monitoring system. *Patent US 6845336B2*. Priority date: 25-06-2002; Grant: 01-18-2005. <https://patents.google.com/patent/US6845336>
15. Judith M. Hushon. Overview of Environmental Expert Systems. *Expert Systems for Environmental Applications*.

- Chapt. 1, P. 1–24. <https://doi.org/10.1021/bk-1990-0431.ch001>; *ACS Symposium Series*. V. 431. Publ. 05.06.1990 <https://pubs.acs.org/doi/abs/10.1021/bk-1990-0431.ch001>
16. Glenn F. Osborne, Simon S. M. Chin, Paul McDonald, Scott Schneider. Artificial intelligence system for genetic analysis. *Patent US 8693751B2*. Priority date: 1999-08-27, 2014-04-08 Grant. <https://patents.google.com/patent/US8693751>
 17. Trinus K. F., Klyuchko O. M. Mediators influence on motoneurons retrogradly marked by primulin. *Physiol. J.* 1984, 30 (6), 730–733. (In Russian).
 18. Aralova N. I., Klyuchko O. M., Mashkin V. I., Mashkina I. V. Algorithmic and program support for optimization of interval hypoxic training modes selection of pilots. *Electronics and Control Systems*. 2017, 2 (52), 85–93.
 19. Aralova N. I., Klyuchko O. M., Mashkin V. I., Mashkina I. V. Mathematic and program models for investigation of reliability of operator professional activity in “Human-Machine” systems. *Electronics and Control Systems*. 2017, 1 (51), 105–113.
 20. Aralova N. I., Klyuchko O. M., Mashkin V. I., Mashkina I. V. Mathematical model for research of organism restoring for operators of continuously interacted systems. *Electronics and Control Systems*. 2016, 3 (49), 100–105.
 21. Aralova N. I., Klyuchko O. M., Mashkin V. I., Mashkina I. V. Investigation of reliability of operators work at fluctuating temperature conditions. *Electronics and Control Systems*. 2016, 2 (48), 132–139.
 22. Plakhotnij S. A., Klyuchko O. M., Krotinova M. V. Information support for automatic industrial environment monitoring systems. *Electronics and Control Systems*. 2016, 1 (47), 19–34.
 23. Onopchuk Yu. M., Aralova N. I., Klyuchko O. M., Beloshitsky P. V. Mathematic models and integral estimation of organism systems reliability in extreme conditions. *Electronics and Control Systems*. 2015, 4 (46), 109–115.
 24. Onopchuk Yu. M., Aralova N. I., Klyuchko O. M., Beloshitsky P. V. Integral estimations of human reliability and working capacity in sports wrestling. *Journal of the Engineering Academy*. 2015, N 3, 145–148. (In Russian).
 25. Klyuchko O. M., Shutko V. N., Navrotskyi D. O., Mikolushko A. M. The set of program models for ecological monitoring technical system based on principles of biophysics. *Electronics and Control Systems*. 2014, 4 (42), 135–142.
 26. Klyuchko O. M., Sheremet D. Yu. Computer simulation of biological nanogenerator functions. *Electronics and Control Systems*. 2014, 2 (40), 103–111.
 27. Klyuchko O. M., Shutko V. N. Computer modeling of auto-oscillating phenomena in neuron complexes. *Electronics and Control Systems*. 2014, 1 (39), 127–132.
 28. Klyuchko O. M., Sheremet D. Yu. Computer modeling of biologic voltage-activated nanostructures. *Electronics and Control Systems*. 2014, 1 (39), 133–139.
 29. Beloshitsky P. V., Klyuchko O. M., Onopchuk Yu. M. Radiation damage of organism and its correction in conditions of adaptation to high-mountain meteorological factors. *Bulletin of NAU*. 2010, N 1, P. 224–231. (In Ukrainian).
 30. Beloshitsky P. V., Klyuchko O. M., Onopchuk Yu., Makarenko M. V. Estimation of psychophysiological functions of a person and operator work in extreme conditions. *Bulletin of NAU*. 2009, N 3, P. 96–104. (In Ukrainian).
 31. Beloshitsky P. V., Klyuchko O. M., Onopchuk Yu., Kolchinska A. Z. Results of research of higher nervous activity problems by Ukrainian scientists in Prielbrussie. *Bulletin of NAU*. 2009, N 2, P. 105–112. (In Ukrainian).
 32. Beloshitsky P. V., Klyuchko O. M., Onopchuk Yu. Results of research of structural and functional interdependencies by Ukrainian scientists in Prielbrussie. *Bulletin of NAU*. 2009, N 1, P. 61–67. (In Ukrainian).
 33. Beloshitsky P. V., Klyuchko O. M., Onopchuk Yu. Results of research of highlands factors influence on health and longevity by Ukrainian scientists in Prielbrussie. *Bulletin of NAU*. 2008, N 4, P. 108–117. (In Ukrainian).
 34. Onopchuk Yu. M., Klyuchko O. M., Beloshitsky P. V. Development of mathematical models basing on researches of Ukrainian scientists at Elbrus. *Bulletin of NAU*. 2008, N 3, P. 146–155. (In Ukrainian).
 35. Beloshitsky P. V., Klyuchko O. M., Onopchuk Yu. Results of research of adaptation problems by Ukrainian scientists in Prielbrussie. *Bulletin of NAU*. 2008, N 1, P. 102–108. (In Ukrainian).
 36. Beloshitsky P. V., Klyuchko O. M., Onopchuk Yu. Results of research of hypoxia problems by Ukrainian scientists in Elbrus region. *Bulletin of NAU*. 2007, N 3–4, P. 44–50. (In Ukrainian).
 37. Beloshitsky P. V., Klyuchko O. M., Onopchuk Yu. Results of medical and biological research of Ukrainian scientists at Elbrus. *Bulletin of NAU*. 2007, N 2, P. 10–16. (In Ukrainian).
 38. Belan P., Gerasimenko O., Tepikin A. Localization of Ca⁺⁺ extrusion sites in pancreatic acinar cells. *Journal of Biological Chemistry*. 1996, V. 271, 7615–7619.
 39. Belan P., Gardner J., Gerasimenko O. Extracellular Ca²⁺ spikes due to secretory events in salivary gland cells. *Journal of Biological Chemistry*. 1998, V. 273, 4106–4111.
 40. Jabs R., Pivneva T., Huttmann K. Synaptic transmission onto hippocampal glial cells with hGFAP promoter activity. *Journal of Cell Science*. 2005, V. 118, 3791–3803.
 41. Gavrilovich M. Spectra image processing and application in biotechnology and pathology.

- Dissertation for Ph.D. *Acta Universitatis Upsaliensis. Upsala*. 2011, 63 p.
42. Perner P., Salvetti O. Advances in Mass Data Analysis of Images and Signals in Medicine, Biotechnology, Chemistry and Food Industry. *Third International Conference, Leipzig, (Germany): Springer*, 2008, *Proceedings*. 2008, 173 p.
 43. Baert P., Meesen G., De Schynkel S., Poffijn A., Oostveldt P. V. Simultaneous in situ profiling of DNA lesion endpoints based on image cytometry and a single cell database approach. *Micron*. 2005, 36 (4), 321–330. <https://doi.org/10.1016/j.micron.2005.01.005>
 44. Berks G., Ghassemi A., von Keyserlingk D. G. Spatial registration of digital brain atlases based on fuzzy set theory. *Comp. Med. Imag. Graph.* 2001, 25 (1), 1–10. [https://doi.org/10.1016/S0895-6111\(00\)00038-0](https://doi.org/10.1016/S0895-6111(00)00038-0)
 45. Nowinski W. L., Belov D. The Cerefy Neuroradiology Atlas: a Talairach–Tournoux atlas-based tool for analysis of neuroimages available over the internet. *NeuroImage*. 2003, 20 (1), 50–57. [https://doi.org/10.1016/S1053-8119\(03\)00252-0](https://doi.org/10.1016/S1053-8119(03)00252-0)
 46. Chaplot S., Patnaik L. M., Jagannathan N. R. Classification of magnetic resonance brain images using wavelets as input to support vector machine and neural network. *Biomed. Signal Process. Control*. 2006, 1 (1), 86–92. <https://doi.org/10.1016/j.bspc.2006.05.002>
 47. Kovalev V. A., Petrou M., Suckling J. Detection of structural differences between the brains of schizophrenic patients and controls. *Psychiatry Research: Neuroimaging*. 2003, 124 (3), 177–189. [https://doi.org/10.1016/S0925-4927\(03\)00070-2](https://doi.org/10.1016/S0925-4927(03)00070-2)
 48. Klyuchko O. M., Hayrutdinov R. R. Modeling of electrical signals propagation in neurons and its nanostructures. *Electronics and control systems*. 2011, 28 (2), 120–124. (In Ukrainian).
 49. Vecht-Lifshitz S. E., Ison A. P. Biotechnological applications of image analysis: present and future prospects. *J. Biotechnol.* 1992, 23 (1), 1–18.
 50. Toga A. W., Thompson P. M. The role of image registration in brain mapping. *Image and Vision Computing*. 2001, 19 (1–2), 3–24.
 51. Shu-Hsien Liao. Expert system methodologies and applications — a decade review from 1995 to 2004. *Expert Systems with Applications*. 2005, 28 (1), 93–103.
 52. Weiskopf N., Scharnowski F., Veit R. Self-regulation of local brain activity using real-time functional magnetic resonance imaging (fMRI). *J. Physiol. Paris*, 2004, 98 (4–6), 357–373.
 53. Yan H., Y. Jiang, J. Zheng The internet-based knowledge acquisition and management method to construct large-scale distributed medical expert systems. *Computer methods and programs in biomedicine*. 2004, 74 (1), 1–10.
 54. Yi M. Y., Jackson J. D., Park J. S. Understanding information technology acceptance by individual professionals: Toward an integrative view. *Information & Management*. 2006, 43 (3), 350–363.
 55. Young R. Genetic toxicology: web-resources. *Toxicology*. 2002, 173 (1–2), 103–121.
 56. Yu C. Methods in biomedical ontology. *J. Biomed. Inform.* 2006, 39 (3), 252–266.
 57. Zhang J., Sun J., Yang Y. Web-based electronic patient records for collaborative medical applications. *Computerized Medical Imaging and Graphics*. 2005, 29 (2–3), 115–124.
 58. Zhou X., Weib J., Xub C.-Z. Quality-of-service differentiation on the Internet: A taxonomy. *J. Network and Computer Applications*. 2007, V. 30, P. 354–383.
 59. Zimowska G. J., Handler A. M. Highly conserved piggyBac elements in Noctuidae species of Lepidoptera. *Insect Biochem. Mol. Biology*. 2006, 36 (5), 421–428.
 60. Carro S. A., Scharcanski J. A framework for medical visual information exchange on the WEB. *Computers in Biology and Medicine*. 2006, 36 (4), 327–338.
 61. Chakravarty M. M., Bertrand G., Hodge C. P., Sadikot A. F., Collins D. L. The creation of a brain atlas for image guided neurosurgery using serial histological data. *NeuroImage*. 2006, 30 (2), 359–376. <https://doi.org/10.1016/j.neuroimage.2005.09.041>
 62. Dikshit A., Wu D., Wu C., Zhao W. An online interactive simulation system for medical imaging education. *Comp. Med. Imag. Graph.* 2005, 29 (6), 395–404. <https://doi.org/10.1016/j.compmedimag.2005.02.001>
 63. Singh R., Schwarz N., Taesombut N., Leea D., Jeongb B., Renambotb L., Lina A. W., Westa R., Otsukae H., Naitof S., Peltiera S. T., Martonea M. E., Nozakid K., Leighb J., Ellisman M. H. Real-time multi-scale brain data acquisition, assembly, and analysis using an end-to-end. *OptIPuter Future Generation Computer Systems*. 2006.
 64. Stefanescu R., Pennec X., Ayache N. Grid powered nonlinear image registration with locally adaptive regularization. *Medical Image Analysis*. 2004, 8 (3), 325–342.
 65. Ma Y., Hof P. R., Grant S. C., Blackband S. J., Bennett R., Slatest L., McGuigan M. D., Benveniste H. A three-dimensional digital atlas database of the adult C57BL/6J mouse brain by magnetic resonance microscopy. *Neuroscience*. 2005, 135 (4), 1203–1215. <https://doi.org/10.1016/j.neuroscience.2005.07.014>
 66. Yu-Len Huang. Computer-aided Diagnosis Using Neural Networks and Support Vector Machines for Breast Ultrasonography. *J. Med. Ultrasound*. 2009, 17 (1), 17–24.
 67. Prachi Damodhar Shahare, Ram Nivas Giri. Comparative Analysis of Artificial Neural Network and Support Vector Machine Classification for Breast Cancer Detection. *International Research Journal of Engineering and Technology (IRJET)*. 2015, 2 (9).

68. *Natrajan R., Sailem H., Mardakheh F. K., Garcia M. F., Tape C. G., Dowsett M., Bakal C., Yuan Y.* Microenvironmental heterogeneity parallels breast cancer progression: a histology–genomic integration analysis. *PLoS medicine*. 2016, 13 (2), e1001961. <https://doi.org/10.1371/journal.pmed.1001961>
69. *Klyuchko O. M.* Brain images in information systems for neurosurgery and neurophysiology. *Electronics and control systems*. 2009, 3 (21), 152–156. (In Ukrainian).
70. *Klyuchko O. M.* Using of images' databases for diagnostics of pathological changes in organism tissues. *Electronics and control systems*. 2009, 2 (20), 62–68. (In Ukrainian).
71. *Klyuchko O. M.* Elements of different level organization of the brain as material for electronic databases with images. *Electronics and control systems*. 2009, 1 (19), 69–75. (In Ukrainian).
72. *Klyuchko O. M., Shutko V. N., Mikolushko A. M., Navrotskyi D. A.* Possibility of images recognition by artificial biotechnical system. *2014 IEEE 3d Intl Conference: MSNMC Proceedings*. 2014, P. 165–169.
73. *Klyuchko O. M., Managadze Yu. L., Pashkivsky A. O.* Program models of 2D neuronal matrix for ecological monitoring and images' coding. *Bulletin of the Engineering Academy*. 2013, N 3–4, P. 77–82. (In Ukrainian).
74. *Klyuchko O. M., Piatchanina T. V., Mazur M. G.* Combined use of relation databases of images for diagnostics, therapy and prognosis of oncology diseases. “Integrated robototechnic complexes”. X IIRTC2017- Conference Proceedings. P. 275–276. (In Ukrainian).
75. *Shutko V. M., Shutko O. M., Kolganova O. O.* Methods and means of compression of information. *Kyiv: Naukova dumka*. 2012, 168 p. (In Ukrainian).
76. *Jecheva V., Nikolova E.* Some clustering-based methodology applications to anomaly intrusion detection systems. *Int. J. Secur. Appl.* 2016, 10 (1), 215–228. <http://dx.doi.org/10.14257/ijasia.2016.10.1.20>
77. *Iakovidis D. K., Maroulis D. E., Karkanis S. A.* Texture multichannel measurements for cancer precursors' identification using support vector machines. *Measurement*. 2004, V. 36, P. 297–313. <https://doi.org/10.1016/j.measurement.2004.09.010>
78. *Nguyen H. Q., Carrieri-Kohlman V., Rankin S. H., Slaughter R., Stulbarg M. S.* Internet-based patient education and support interventions: a review of evaluation studies and directions for future research. *Comp. Biol. Med.* 2004, 34 (2), 95–112. [https://doi.org/10.1016/S0010-4825\(03\)00046-5](https://doi.org/10.1016/S0010-4825(03)00046-5)
79. *Jézéquel P., Loussouarn L., Guérin-Charbonnel C., Champion L., Vanier A., Gouraud W., Lasla H., Guette C., Valo I., Verrière V., Campone M.* Gene-expression molecular subtyping of triple-negative breast cancer tumours: importance of immune response. *Breast Cancer Res.* 2015, 17 (1), 43. <https://doi.org/10.1186/s13058-015-0550-y>
80. *Bozhenko V. K.* Multivariable analysis of laboratory blood parameters for obtaining diagnostic information in experimental and clinical oncology. The dissertation author's abstract on scientific degree editions. *Dc. Med. Study. Moscow*. 2004. (In Russian).
81. *Ko J. H., Ko E. A., Gu W., Lim I., Bang H., Zhou T.* Expression profiling of ion channel genes predicts clinical outcome in breast cancer. *Mol. Cancer*. 2013, 12 (1), 106. <https://doi.org/10.1186/1476-4598-12-106>
82. *Kawai M., Nakashima A., Kamada S., Kikkawa U.* Midostaurin preferentially attenuates proliferation of triple-negative breast cancer cell lines through inhibition of Aurora kinase family. *J. Biomed. Sci.* 2015, 22 (1), 48. <https://doi.org/10.1186/s12929-015-0150-2>
83. *Uhr K., Wendy J. C., Prager-van der Smissen, Anouk A. J. Heine, Bahar Ozturk, Marcel Smid, Hinrich W. H. Ghlmann, Agnes Jager, John A. Foekens, John W. M. Martens.* Understanding drugs in breast cancer through drug sensitivity screening. *SpringerPlus*. 2015, 4 (1), 611. <https://doi.org/10.1186/s40064-015-1406-8>
84. *Onopchuk Yu. M., Biloshitsky P. V., Klyuchko O. M.* Development of mathematical models based on the results of researches of Ukrainian scientists at Elbrus. *Visnyk NAU*. 2008, N 3, P. 146–155. (In Ukrainian).
85. *Ankur Poudel, Dhruba Bahadur Thapa, Manoj Sapkota.* Cluster Analysis of Wheat (*Triticum aestivum* L.) Genotypes Based Upon Response to Terminal Heat Stress. *Int. J. Appl. Sci. Biotechnol.* 2017, 5 (2), 188–193. <https://dx.doi.org/10.3126/ijasbt.v5i2.17614>
86. *Zaslavsky L., Ciufu S., Fedorov B., Tatusova T.* Clustering analysis of proteins from microbial genomes at multiple levels of resolution. *BMC Bioinform.* 2016, 17 (8), 276. Published online 2016 Aug 31. <https://doi.org/10.1186/s12859-016-1112-8>
87. *Zhou J., Richardson A. J., Rudd K. E.* EcoGene-RefSeq: EcoGene tools applied to the RefSeq prokaryotic genomes. *Bioinformatics*. 2013, 29 (15), 1917–1918. Published: 04 June 2013. <https://doi.org/10.1093/bioinformatics/btt302>
88. *Zhang J., Wu G., Hu X., Li S., Hao S.* A Parallel Clustering Algorithm with MPI — MKmeans. *J. Comput.* 2013, 8 (1), 1017. <https://doi.org/10.1109/PAAP.2011.17>
89. *Tatusova T., Zaslavsky L., Fedorov B., Haddad D., Vatsan A., Ako-adjei D., Blinkova O., Ghazal H.* Protein Clusters. *The NCBI Handbook [Internet]*. 2nd edition. Available at <https://www.ncbi.nlm.nih.gov/books/NBK242632>
90. *Anderson J. G.* Evaluation in health informatics: computer simulation. *Computers in Biology and Medicine*. 2002, 32 (3), 151–164. [https://doi.org/10.1016/S0010-4825\(02\)00012-4](https://doi.org/10.1016/S0010-4825(02)00012-4)

91. Aruna P., Puviarasan N., Palaniappan B. An investigation of neuro-fuzzy systems in psychosomatic disorders. *Exp. Syst. Appl.* 2005, 28 (4), 673–679. <https://doi.org/10.1016/j.eswa.2004.12.024>
92. Bange M. P., Deutscher S. A., Larsen D., Linsley D., Whiteside S. A handheld decision support system to facilitate improved insect pest management in Australian cotton systems. *Comp. Electron. Agricult.* 2004, 43 (2), 131–147. <https://doi.org/10.1016/j.compag.2003.12.003>
93. Beaulieu A. From brainbank to database: the informational turn in the study of the brain. *Stud. Hist. Phil. Biol. Biomed. Sci.* 2004, V. 35, P. 367–390. <https://doi.org/10.1016/j.shpsc.2004.03.011>
94. Bedathur S. J., Haritsa J. R., Sen U. S. The building of BODHI, a bio-diversity database system. *Inform. Syst.* 2003, 28 (4), 347–367. [https://doi.org/10.1016/S0306-4379\(02\)00073-X](https://doi.org/10.1016/S0306-4379(02)00073-X)
95. Brake I. Unifying revisionary taxonomy: insect exemplar groups. *Abstr. XV SEL Congr. Berlin (Germany)*. 2007.
96. Braxton S. M., Onstad D. W., Dockter D. E., Giordano R., Larsson R., Humber R. A. Description and analysis of two internet-based databases of insect pathogens: EDWIP and VIDIL. *J. Invertebr. Pathol.* 2003, 83 (3), 185–195. [https://doi.org/10.1016/S0022-2011\(03\)00089-2](https://doi.org/10.1016/S0022-2011(03)00089-2)
97. Breaux A., Cochrane S., Evens J., Martindale M., Pavlike B., Suera L., Benner D. Wetland ecological and compliance assessments in the San Francisco Bay Region, California, USA. *J. Environm. Manag.* 2005, 74 (3), 217–237.
98. Budura A., hilippeCudr-Mauroux P., Aberer K. From bioinformatic web portals to semantically integrated Data Grid networks. *Future Generation Computer Systems*. 2007, 23 (3), 281–522. <https://doi.org/10.1016/j.jenvman.2004.08.017>
99. Burns G., Stephan K. E., Ludäscher B., Gupta A., Kötter R. Towards a federated neuroscientific knowledge management system using brain atlases. *Neurocomputing*. 2001, V. 3840, P. 1633–1641. [https://doi.org/10.1016/S0925-2312\(01\)00520-3](https://doi.org/10.1016/S0925-2312(01)00520-3)
100. Butenko S., Wilhelm W. E. Clique-detection models in computational biochemistry and genomics. *Eur. J. Oper. Res.* 2006, 173 (1), 117. <https://doi.org/10.1016/j.ejor.2005.05.026>
101. Carro S. A., Scharcanski J. Framework for medical visual information exchange on the WEB. *Comp. Biol. Med.* 2006, 36 (4), 327–338. <https://doi.org/10.1016/j.compbiomed.2004.10.004>
102. Chau M., Huang Z., Qin J., Zhou Y., Chen H. Building a scientific knowledge web portal: The NanoPort experience. *Decision Support Systems*. 2006. <https://doi.org/10.1016/j.dss.2006.01.004>
103. Chen M., Hofestädt R. A medical bioinformatics approach for metabolic disorders: Biomedical data prediction, modeling, and systematic analysis. *J. Biomed. Inform.* 2006, 39 (2), 147–159. <https://doi.org/10.1016/j.jbi.2005.05.005>
104. Chli M., De Wilde P. Internet search: Subdivision-based interactive query expansion and the soft semantic web Applied Soft Computing. 2006. <https://doi.org/10.1016/j.asoc.2005.11.003>
105. Despont-Gros C., Mueller H., Lovis C. Evaluating user interactions with clinical information systems: A model based on human-computer interaction models. *J. Biomed. Inform.* 2005, 38 (3), 244–255. <https://doi.org/10.1016/j.jbi.2004.12.004>
106. Despont-Gros C., Mueller H., Lovis C. Evaluating user interactions with clinical information systems: a model based on human-computer interaction models. *J. Biomed. Inform.* 2005, 38 (3), 244–255. <https://doi.org/10.1016/j.jbi.2004.12.004>
107. Marios D., Dikaiakos M. D. Intermediary infrastructures for the World Wide Web. *Comp. Networks*. 2004, V. 45, P. 421–447. <https://doi.org/10.1016/j.comnet.2004.02.008>
108. Dimitrov S. D., Mekenyan O. G., Sinks G. D., Schultz T. W. Global modeling of narcotic chemicals: ciliate and fish toxicity. *J. Mol. Struct.: Theochem.* 2003, 622 (12), 63–70. [https://doi.org/10.1016/S0166-1280\(02\)00618-8](https://doi.org/10.1016/S0166-1280(02)00618-8)
109. Dong Y., Zhuang Y., Chen K., Tai X. A hierarchical clustering algorithm based on fuzzy graph connectedness. *Fuzzy Sets. Syst.* 2006, V. 157, P. 1760–1774. <https://doi.org/10.1016/j.fss.2006.01.001>
110. Duan Y., Edwards J. S., Xu M. X. Web-based expert systems: benefits and challenges. *Inf. Manag.* 2005, 42 (6), 799–811. <https://doi.org/10.1016/j.im.2004.08.005>
111. Essen van D. C. Windows on the brain: the emerging role of atlases and databases in neuroscience. *Curr. Opin. Neurobiol.* 2002, 12 (5), 574–579. [https://doi.org/10.1016/S0959-4388\(02\)00361-6](https://doi.org/10.1016/S0959-4388(02)00361-6)
112. Fellbaum C., Hahn U., Smith B. Towards new information resources for public health From Word Net to Medical Word Net. *J. Biomed. Inform.* 2006, 39 (3), 321–332. <https://doi.org/10.1016/j.jbi.2005.09.004>
113. Ferraris M., Frixione P., Squarcia S. Network oriented radiological and medical archive. *Comp. Physics Commun.* 2001, V. 140, P. 226–232. [https://doi.org/10.1016/S0010-4655\(01\)00273-9](https://doi.org/10.1016/S0010-4655(01)00273-9)
114. Flower D. R., Attwood T. K. Integrative bioinformatics for functional genome annotation: trawling for G protein-coupled receptors. *Semin. Cell. Dev. Biol.* 2004, 15 (6), 693–701. <https://doi.org/10.1016/j.semdb.2004.09.008>

115. Fink E., Kokku P. K., Nikiforou S., Hall L. O., Goldgof D. B., Krischer J. P. Selection of patients for clinical trials: an interactive web-based system. *Art. Intell. Med.* 2004, 31 (3), 241–254. <https://doi.org/10.1016/j.artmed.2004.01.017>
116. Fitzpatrick M. J., Ben-Shahar Y., Smid H. M., Vet L. E., Robinson G. E., Sokolowski M. B. Candidate genes for behavioural ecology. *Trend Ecol. Evol.* 2005, 20 (2), 96–104. <https://doi.org/10.1016/j.tree.2004.11.017>
117. Fox J., Alabassi A., Patkar V., Rose T., Black E. An ontological approach to modelling tasks and goals. *Comp. Biol. Med.* 2006, V. 36, P. 837–856. <https://doi.org/10.1016/j.compbiomed.2005.04.011>
118. Fu Zetian, Xu Feng, Zhou Yun, Shuan X. Z. Pig-vet: a web-based expert system for pig disease diagnosis. 2006. <https://doi.org/10.1016/j.eswa.2005.01.011>
119. Gaulton A., Attwood T. K. Bioinformatics approaches for the classification of G-protein-coupled receptors. *Curr. Opin. Pharmacol.* 2003, 3 (2), 114–120. [https://doi.org/10.1016/S1471-4892\(03\)00005-5](https://doi.org/10.1016/S1471-4892(03)00005-5)
120. Gevrey M., Worner S., Kasabov N., Pitt J., Giraudel J. L. Estimating risk of events using SOM models: A case study on invasive species establishment. *Ecol. Modell.* 2006, 197 (34), 361–372. <https://doi.org/10.1016/j.ecolmodel.2006.03.032>
121. Glenisson P., Glänzel W., Janssens F., Moor B. D. Combining full text and bibliometric information in mapping scientific disciplines. *Inf. Proc. Manag.* 2005, 41 (6), 1548–1572. <https://doi.org/10.1016/j.ipm.2005.03.021>
122. Goldys E. M. Fluorescence Applications in Biotechnology and the Life Sciences. USA: John Wiley & Sons. 2009, 367 p.
123. Graham C. H., Ferrier S., Huettman F., Moritz C., Peterson A. T. New developments in museum-based informatics and applications in biodiversity analysis. *Trend. Ecol. Evol.* 2004, 19 (9), 497–503. <https://doi.org/10.1016/j.tree.2004.07.006>
124. Gruber T. R. A translation approach to portable ontologies. *Knowledge Acquisition.* 1993, 5 (2), 199–220. <https://doi.org/10.1006/knac.1993.100810.1006/knac.1993.1008>
125. Hirano S., Sun X., Tsumoto S. Comparison of clustering methods for clinical databases. *Inform. Sci.* 2004, 159 (34), 155–165. <https://doi.org/10.1016/j.ins.2003.03.011>
126. Hong Yu., Hatzivassiloglou V., Rzhetsky A., Wilbur W. J. Automatically identifying gene/protein terms in MEDLINE abstracts. *J. Biomed. Inform.* 2002, 35 (56), 322–330. [https://doi.org/10.1016/S1532-0464\(03\)00032-7](https://doi.org/10.1016/S1532-0464(03)00032-7)
127. Horn W. AI in medicine on its way from knowledge-intensive to data-intensive systems. *Artificial Intelligence in Medicine. Elsevier.* 2001, 23 (1), 512. [https://doi.org/10.1016/S0933-3657\(01\)00072-0](https://doi.org/10.1016/S0933-3657(01)00072-0)
128. Hsi-Chieh Lee, Szu-Wei Huang, Li E. Y. Mining protein–protein interaction information on the internet. *Exp. Syst. Appl. Elsevier.* 2006, 30 (1), 142–148. <https://doi.org/10.1016/j.eswa.2005.09.083>
129. Jabs R., Pivneva T., Huttmann K., Wyczynski A., Nolte C., Kettenmann H., Steinhäuser C. Synaptic transmission onto hippocampal glial cells with hGFAP promoter activity. *J. Cell Sci.* 2005, V. 118, P. 3791–3803. <https://doi.org/10.1242/jcs.0251510.1242/jcs.0251510>
130. Johnson S. B., Friedman R. Bridging the gap between biological and clinical informatics in a graduate training program. *J. Biomed. Inform.* 2007, 40 (1), 59–66. Epub. 2006 Mar 15. <https://doi.org/10.1016/j.jbi.2006.02.011>
131. Kaiser M., Hilgetag C. C. Modelling the development of cortical systems networks. *Neurocomputing.* 2004, V. 5860, P. 297–302. <https://doi.org/10.1016/j.neucom.2004.01.059>
132. Yan H., Jiang Y., Zheng J. The internet-based knowledge acquisition and management method to construct large-scale distributed medical expert system. *Comp. Meth. Progr. Biomed.* 2004, 74 (1), 1–10.
133. Kannathal N., Acharya U. R., Lim C. M., Sadasivan P. K. Characterization of EEG. A comparative study. *Comp. Meth. Progr. Biomed.* 2005, 80 (1), 17–23. <https://doi.org/10.1016/j.cmpb.2005.06.005>
134. Koh W., McCormick B. H. Brain microstructure database system: an exoskeleton to 3D reconstruction and modelling. *Neurocomputing.* 2002, V. 4446, P. 1099–1105. [https://doi.org/10.1016/S0925-2312\(02\)00426-5](https://doi.org/10.1016/S0925-2312(02)00426-5)
135. Koh W., McCormick B. H. Registration of a 3D mouse brain atlas with brain microstructure data. *Neurocomputing.* 2003, V. 5254, P. 307–312. [https://doi.org/10.1016/S0925-2312\(02\)00793-2](https://doi.org/10.1016/S0925-2312(02)00793-2)
136. Kulish V., Sourin A., Sourina O. Human electroencephalograms seen as fractal time series: Mathematical analysis and visualization. *Comp. Biol. Med.* 2006, 36 (3), 291–302. <https://doi.org/10.1016/j.compbiomed.2004.12.003>
137. Lubitz von D., Wickramasinghe N. Networkcentric healthcare and bioinformatics: Unified operations within three domains of knowledge. *Exp. Syst. Appl.* 2006, 30 (1), 11–23. <https://doi.org/10.1016/j.eswa.2005.09.069>
138. Martin-Sanchez F., Iakovidis I., Norager S., Maojo V., de Groen P., Van der Lei J., Jones T., Abraham-Fuchs K., Apweiler R., Babic A., Baud R., Breton V., Cinquin P., Doupi P., Dugas M., Eils R., Engelbrecht R., Ghazal P., Jehenson P., Kulikowski C., Lampe K., De Moor G., Orphanoudakis S., Rossing N., Sarachan B., Sousa A., Spekowius G., Thireos G., Zahlmann G., Zvárová J., Hermosilla I., Vicente F. J. Synergy between medical

- informatics and bioinformatics: facilitating genomic medicine for future health care. *J. Biomed. Inform.* 2004, 37 (1), 30–42. <https://doi.org/10.1016/j.jbi.2003.09.003>
139. Masseroli M., Visconti A., Bano S. G., Pinciroli F. He@lthCo-op: a web-based system to support distributed healthcare co-operative work. *Comp. Biol. Med.* 2006, 36 (2), 109–127. <https://doi.org/10.1016/j.compbiomed.2004.09.005>
 140. Moon S., Byun Y., Han K. FSDB: A frameshift signal database. *Comp. Biol. Chem.* 2007, 31 (4), 298–302. <https://doi.org/10.1016/j.compbiolchem.2007.05.004>
 141. Orgun B., Vu J. HL7 ontology and mobile agents for interoperability in heterogeneous medical information systems. *Comp. Biol. Med.* 2006, 36 (78), 817–836. <https://doi.org/10.1016/j.compbiomed.2005.04.010>
 142. Pérez-Rey D., Maojo V., García-Remesal M., Alonso-Calvo R., Billhardt H., Martín-Sánchez F., Sousa A. Ontofusion: Ontology-based integration of genomic and clinical databases. *Comp. Biol. Med.* 2006, 36 (78), 712–730. <https://doi.org/10.1016/j.compbiomed.2005.02.004>
 143. Krishtal O. A., Kiskin N. I., Tsyndrenko A. Ya., Klyuchko E. M. Pharmacological properties of amino acid receptors in isolated hippocampal neurons. In: Receptors and ion channels. Ed. By Ovchinnikov Y. A., Hucho F. Berlin-New York: Walter de Gruyter. 1987, P. 127–137.
 144. Klyuchko E. M., Klyuchko Z. F., Beloshitsky P. V. Some adaptation characteristics of insects in mountains of Prielbrusie. *Nalchik (Russia), "Hypoxia: automatic analysis of hypoxic states of healthy people and sick ones"*. 2005, V. 1, P. 137–140. (In Russian).
 145. Klyuchko O. M. Biophysical methods use for the elaboration of new system for ecological monitoring of airports' environment. *Bulletin of Engineering Academy.* 2014, 2, 72–76. (In Ukrainian).
 146. Klyuchko O. M. Development of new monitoring system with data protection for conditions of Ukrainian Polyssia. *Bulletin of Engineering Academy.* 2014, 2, 239–246. (In Ukrainian).
 147. Gonchar O., Klyuchko E., Mankovskaya I. Role of complex nucleosides in the reversal of oxidative stress and metabolic disorders induced by acute nitrite poisoning. *Indian Journal of Pharmacology.* 2006, 38 (6), 414–418. <http://www.ijp-online.com/article.asp?issn=0253-7613;year=2006;volume=38;issue=6;spage=414;epage=418;au last=Gonchar>
 148. Gonchar O., Klyuchko E., Seredenko M., Oliynyk S. Corrections of prooxidant — antioxidant homeostasis of organism under hypoxia of different genesis by yackton, new pharmacological preparation. *Sofia (Bulgaria), Acta Physiol. Pharmacol. Bulg.* 2003, V. 27, P. 53–58.
 149. Klyuchko O., Klyuchko Z., Lizunova A. Electronic Noctuidae database: some problems and solutions. *Proceed. 16th European Congress of Lepidopterology. Cluj (Romania).* 2009, P. 31–32.
 150. Klyuchko O., Klyuchko Z., Lizunova A. Noctuidae fauna of Ukrainian Karpathy: results of monitoring (1956–2008). *Proceed. 16th European Congress of Lepidopterology. Cluj (Romania).* 2009, P. 31.
 151. Klyuchko O. M., Klyuchko Z. F., Lizunova A. G. Development Of Database For Noctuidae Species In Ukraine. *5-th International Conference on the Biology of Butterflies, Roma.* 2007.
 152. Klyuchko Z. F., Klyuchko O. M. Diversity and biogeography of Noctuidae Species In Ukraine. *5-th International Conference on the Biology of Butterflies, Roma.* 2007.
 153. Klyuchko O. M., Beloshitsky P. V. Investigation of insect adaptation characteristics in Prielbrusie in 2004–2005. *Mater. VIII World Congress of International Society for Adaptive Medicine (ISAM). Moscow (Russia).* 2006, P. 165–166.
 154. Beloshitsky P. V., Klyuchko O. M. Contribution of Sirotinin's school into adaptation medicine. *Mater. VIII World Congress of International Society for Adaptive Medicine (ISAM). Moscow (Russia).* 2006, P. 158.
 155. Klyuchko O. M., Klyuchko Z. F. Ukrainian Noctuidae Database. *Mater. of XIV SEL Congress. Roma (Italy).* 2005, P. 49.
 156. Klyuchko Z. F., Klyuchko O. M. Noctuidae (Lepidoptera) of Donbass, Ukraine. *Mater. of XIV SEL Congress. Roma (Italy).* 2005, P. 41–42.
 157. Beloshitsky P., Klyuchko O., Onopchuck Yu., Onopchuck G. Mathematic model for hypoxic states development for healthy people and ones with ischemic heart disease. *High altitude medicine and biology: Mater. ISMM Congress. Beijing (China).* 2004, V. 5, P. 251.
 158. Beloshitsky P., Klyuchko O., Kostyuk O., Beloshitsky S. Peculiarities of high mountain factors influence on organism. *High altitude medicine and biology: Mater. ISMM Congress. Beijing (China).* 2004, V. 5, P. 250.
 159. Gonchar O., Klyuchko O., Beloshitsky P. Ways of myocardial metabolic disorders correction at hypoxia by new pharmacological preparations. *High altitude medicine and biology: Mater. ISMM Congress. Beijing (China).* 2004, V. 5, P. 249.
 160. Gonchar O., Klyuchko O., Seredenko M., Oliynyk B. Correction of metabolic disorders at hypoxia by new pharmacological preparations. *Mater. 3 FEPS Congress. Nice (France).* 2003, P. 228.
 161. Troyan V., Klyuchko O., Taran N. About some ways to change gender standards. *Standard: abweichung: Mater. Intl.*

- Kongress in Natur wissenschaft und Technik. Berlin (Germany)*. 2003, P. 208.
162. Seredenko M., Gonchar O., Klyuchko O., Oliylyk S. Peculiarities of prooxidant — antioxidant balance of organism under hypoxia of different genesis and its corrections by new pharmacological preparations. *Acta Physiologica Hungarica. Budapest (Hungary)*. 2002, 89 (1–3), 292.
 163. Klyuchko O. M., Kiskin N. I., Krishtal O. A., Tsyndrenko A. Ya. Araneidae toxins as antagonists of excitatory amino acid responses in isolated hippocampal neurons. *X School on biophysics of membrane transport. Szczyrk (Poland)*. 1990, V. 2, P. 271.
 164. Akaike N., Kawai N., Kiskin N. I., Krish-tal O. A., Tsyndrenko A. Ya., Klyuchko O. M. Spider toxin blocks excitatory amino acid responses in isolated hippocampal pyramidal neurons. *Neurosci. Lett.* 1987, V. 79, P. 326–330.
 165. Aralova N. I., Klyuchko O. M. Mathematic modeling of functional self-organization of pilots' respiratory systems. "Integrated intellectual robototechnical complexes" — "IIRTC2018-": Materials of XI Intl. Scient. Tech. Conference. 2018, P. 268–269. (In Ukrainian).
 166. Klyuchko Z. F., Klyuchko O. M. Moths (*Lepidoptera: Noctuidae* s. l.) of Cherkasska Region of Ukraine according to results of long-term monitoring. *Eversmannia*. 2014, N 37, P. 32–49. (In Russian).
 167. Klyuchko Z. F., Klyuchko O. M. Analysis of moth fauna taxonomic structure (*Lepidoptera: Noctuidae* s. l.) of Ukraine according to monitoring data. *Eversmannia*. 2014, 33 (3), 41–45. (In Russian).
 168. Klyuchko Z. F. *Noctuidae of Ukraine*. Kyiv: Raevsky Publishing. 2006. (In Ukrainian).
 169. Klyuchko Z. F., Klyuchko O. M. Monitoring of the diversity of *Noctuidae* (*Lepidoptera*) fauna in Ukrainian Polissia. "Nature of Polissia: investigation and protection": Materials of Intl. Scient. Conference. 2014, P. 498–502. (In Ukrainian).
 170. Klyuchko Z. F., Klyuchko O. M., Lizunova A. G. Monitoring of *Noctuidae* fauna of Ukraine using electronic information systems. "Nature of Polissia: investigation and protection": Materials of Intl. Scient. Conference. 2014, P. 261–265. (In Ukrainian).
 171. Klyuchko O. M., Pyatchanina T. V., Mazur M. G. Methods of mathematics and bioinformatics in contemporary oncology. *Materials of World Congress "Aviation in the XXI c.", 10-12 Oct 2018, Kyiv*. P. 6.2.10–6.2.14. <http://conference.nau.edu.ua/index.php/Congress/Congress2018/paper/viewFile/5014/4327>
 172. Klyuchko E. M., Tsyndrenko A. Ya. The method for dissociation of hippocampal cells. *Patent 1370136 USSR, C12N 5/00*. Priority: 31.01.1986; Issued: 30.01.1988, Bull. 4, 3 p. <http://www.findpatent.ru/patent/137/1370136.html> http://www.findpatent.ru/img_show/6580725.html
 173. Klyuchko O. M., Biletsky A. Ya., Navrotskyi D. O. Method of bio-sensor test system application. *Patent UA 129923 U, G01N33/00, G01N33/50, C12Q 1/02*. Priority: 22.03.2018, u201802896, Issued: 26.11.2018, Bull. 22, 7 p. (In Ukrainian). <http://base.uipv.org/searchINV/search.php?action=viewdetails&IdClaim=252946IdClaim=252946>
 174. Klyuchko O. M., Biletsky A. Ya., Navrotskyi D. O. Method of application of biotechnical monitoring system with biosensor (bio-sensor test system). *Patent UA 132245 U; G01N33/50*. Priority: 22.03.2018 u201802893, Issued: 25.02.2019, Bull. 4, 7 p. (In Ukrainian). <http://base.uipv.org/searchINV/search.php?action=viewdetails&IdClaim=255843>
 175. Klyuchko O. M., Biletsky A. Ya., Navrotskyi D. O. Method of application of biotechnical monitoring system with biosensor and sub-system for optical registration. *Patent UA 129922 U, G01N33/50*. Priority: 22.03.2018, u201802894; Issued: 26.11.2018, Bull. 22, 10 p. (In Ukrainian). <http://base.uipv.org/searchINV/search.php?action=viewdetails&IdClaim=252945&chapter=descriptionchapter=description>
 176. Klyuchko O. M. Method of application of biotechnical monitoring system for bioindicators' accounting with biosensor and sub-system for optical registration. *Patent UA 129987 U, G01N33/00, C12Q 1/02, C12N 15/00*. Priority: 27.04.2018, u201804662; Issued: 26.11.2018, Bull. 22, 11 p. (In Ukrainian). <https://base.uipv.org/searchINV/search.php?action=viewdetails&IdClaim=253010IdClaim=253010>
 177. Klyuchko O. M. Method for cells' dissociation. *Patent UA 130672 U, G01N33/00, C12Q 1/02, C12N 15/00*. Priority: 27.04.18, u201804668, Issued: 26.12.2018, Bull. 24, 7p. (In Ukrainian). <https://base.uipv.org/searchINV/search.php?action=viewdetails&IdClaim=253856&chapter=descriptionchapter=description>
 178. Klyuchko O. M., Biletsky A. Ya., Navrotskyi D. O. Method of application of biotechnical monitoring system with expert subsystem and biosensor. *Patent UA 131863 U; G01N33/00, C12Q 1/02, C12N 15/00*. Priority: 27.04.18, u201804663, Issued: 11.02.2019, Bull. 3, 7p. (In Ukrainian). <https://base.uipv.org/searchINV/search.php?action=viewdetails&IdClaim=255364>
 179. Klyuchko O. M. Method of qualitative analysis of chemical substances. *Patent UA 131016 U, G01N33/50, G01N21/78, C12Q 1/60*. Priority: 11.05.2018, u201805174, Issued: 10.01.2019, Bull. 1. (In Ukrainian). <https://base.uipv.org/>

- searchINV/search.php?action=viewdetails&IdClaim=254309”IdClaim=254309
180. Klyuchko O. M., Biletsky A. Ya., Navrotskyi D. A. Method of quantitative analysis of chemical substances. *Patent UA 131524 U; G01N33/50, G01N21/78, C12Q 1/60*. Priority: 11.05.2018, u201805175, Issued: 25.01.2019, Bull. 2, 10p. (In Ukrainian). <http://base.uipv.org/searchINV/search.php?action=viewdetails&IdClaim=254915>
181. Klyuchko O. M., Biletsky A. Ya. Method of qualitative analysis of chemical substances for the influence on electrical currents in bioobjects. *Patent UA; G01N 33/50, G01N 21/78, C12Q 1/60*. Priority: May 2018, u201806345. (In Ukrainian).
182. Klyuchko O. M., Biletsky A. Ya. Method of qualitative analysis of hydrocarbons with a high and toxic effect on bioobjects. *Patent UA; G01N 33/50, G01N 21/78, C12Q 1/60*. Priority: May 2018, u201806342. (In Ukrainian).
183. Klyuchko O. M., Biletsky A. Ya., Navrotskyi D. O. Method of monitoring of chemical substances' influences on organisms in few time intervals. *Patent UA; G01N33/00, C12Q 1/02*. Priority: 14.12.2018, u201812443. (In Ukrainian).
184. Hardy P. B., Sparks T. H., Isaak N. J. Specialism for larval and adult consumer resources among Britttish butterflies: implications for conservation. *Biological Conservation*. 2007, 138 (3–4), 440–452.
185. Dennis R. L. H., Shreeve T. G., Sparks T. H. A comparison of geographical and neighbourhood models for improving atlas databases. The case of the French butterfly atlas. *Biological Conservation*. 2002, 108 (2), 143–159.
186. Ravlin F. W. Development of monitoring and decision-support systems for integrated pest management of forest defoliators in North America. *Forest Ecology and Management*. 1991, N 39, P. 3–13.
187. Mahaman B. D., Harizanis P., Filis I., Antonopoulou A. Yialourisa C. P., Sideridisa A. B. A diagnostic expert system for honeybee pests. *Computers and Electronics in Agriculture*. 2002, 36 (1), 17–31.
188. Murali N. S., Percy-Smith A. Database management system for monitoring and warning of codling moth (*Cydia pomonella*) and carrot fly (*Psila rosae*). *Computers and Electronics in Agriculture*. 1991, 6 (3), 267–272.
189. Drake V. A., Wang H. K., Harman I. T. Insect monitoring radar: remote and network operation. *Computers and Electronics in Agriculture*. 2002, 35 (2–3), 77–94.
190. Franhuck G. M., Isaenko V. M. Ecology, aviation and cosmos. *Kyiv: NAU*. 2005, 456 p. (In Ukrainian).
191. Nemtzov V. I., Nemtzov A. V. Analytical system for complex analysis and taking of probes of biophysical aerosols. *Patent RU 2145706*. Priority date: 11.12.1997, Issued: 20.02.2000. <http://ru-patent.info/21/45-49/2145706.html> (In Russian)
192. Alekseev S. P., Kursin S. B., Yatsenko S. B. Method for the region's ecological state data collection and an automated system of ecological monitoring and emergency monitoring of the regional environment. *Patent RU 2443001C1*. Priority date: 2010-08-05. Filed: 2010-08-05. Issued: 2012-02-20. <https://patents.google.com/patent/RU2443001C1/en?q=patent&q=ecology&q=q=qualitative&q=quantitative+analysis&page=3>
193. Owe Orwar, Jardemark Kent. Biosensors and methods of using the same. *Patent US 20020182642A1, DE69832381D1*. Claimed: 19.6.2002; Published 5.12. 2002. <https://www.google.com/patents/US20020182642>
194. Deisseroth K., Zhang Feng, Gradinaru V. Light-sensitive ion-passing molecules. *Patent US 9,604,073 B2*. Priority Date: 03.17.2010; Filed: 05.12.2016. Issued: 03.28.2017. <https://insight.rpxcorp.com/pat/US9604073B2>
195. Klyuchko O. M., Biletsky A. Ya., Shutko V. N. Method for constructing and testing of physical molecular memory in anisotropic media with molecules — derivatives of phenol. *Patent UA; H01B1/121, G01N33/00, C12Q 1/02*.
196. Patent UA; Priority: 14.12.2018, u201812430 (In Ukrainian).
197. Klyuchko O. M., Biletsky A. Ya., Lizunov G. V., Shutko V. N. Method of electrical signals generating by bio-elements in the technical hybrid system. A61N1/326, G01N33/00, C12Q 1/02. *Patent UA; Priority: 14.12.2018, u201812442 (In Ukrainian)*.
198. Klyuchko O. M., Biletsky A. Ya., Lizunov G. V., Shutko V. N. Method for application of the system of large-scale monitoring of bioobjects with possibility of their radar control. G01N33/00, G01S13/88, C12N 15/00. *Patent UA; Priority: 14.12.2018, u201812444 (In Ukrainian)*.
199. Klyuchko O. M., Biletsky A. Ya., Lizunov G. V., Piankova O. V. Method of application of biosensor test-system with databases. G01N33/00, C12Q 1/02. *Patent UA; Priority: 17.01.2019, u201900476 (In Ukrainian)*.
200. Klyuchko O. M., Biletsky A. Ya., Lizunov G. V., Piankova O. V. Method of application of monitoring system with biosensor and databases. G01N33/00, C12Q 1/02, G06F11/20. *Patent UA; Priority: 17.01.2019, u201900476 (In Ukrainian)*.
201. Nikolov N., Visone R., Nesteruk I., Rasponi M., Redaelly A. A new algorithm to analyze the video data of cell contractions in microfluidic platforms. *Innov Biosyst Bioeng*. 2018; 2(2): 74–83. <https://doi.org/10.20535/ibb.2018.2.2.128477>
202. Umanets V. S., Voynyk B. A., Pavlov V. A., Nاستenko I. A. Estimation of algorithms efficiency in the task of biological objects clustering. *Innov. Biosyst. Bioeng*. 2018; 2(2):84-9. <https://doi.org/10.20535/ibb.2018.2.2.133466>

**БІОТЕХНІЧНІ ІНФОРМАЦІЙНІ
СИСТЕМИ ДЛЯ МОНІТОРИНГУ
ХІМІЧНИХ РЕЧОВИН
У НАВКОЛИШНЬОМУ СЕРЕДОВИЩІ:
БІОФІЗИЧНИЙ ПІДХІД**

О. М. Ключко

Інститут експериментальної патології,
онкології та радіобіології
ім. Р. Є. Кавецького НАН України, Київ

E-mail: kelenaxx@ukr.net

Проаналізовано новітні біотехнічні системи екологічного моніторингу довкілля, що базуються на використанні сучасних інформаційних і комп'ютерних технологій та наявних баз даних хімічних речовин. Зокрема, розглянуто такі сучасні біофізичні методи досліджень, як імітаційне та програмне моделювання, що враховують результати автора, одержані в експериментах з реєстрацією хемочутливих трансмембранних електричних струмів у нейронах у режимі фіксації потенціалу, застосуванням флуоресцентних нейронних маркерів та обліком організмів-біоіндикаторів. Розроблені системи та методи дають змогу виявити та ідентифікувати небезпечні для живих організмів речовини і зробити висновки щодо їхнього можливого біологічного впливу. Функціонування біотехнічних інформаційних систем моніторингу довкілля проаналізовано в широкому часовому діапазоні з використанням сучасних баз даних, експертних підсистем та інтерфейсів, здатних ідентифікувати різні типи хімічних речовин. Показано, що за такого системного екологічного моніторингу існує можливість вивчати та прогнозувати наслідки дії речовин упродовж тривалого часу — від перших моментів впливу на окремі клітини організму до місяців і років після впливу на весь організм.

Ключові слова: біотехнічна інформаційна система моніторингу, забруднення довкілля, біоіндикатори, бази даних.

**БИОТЕХНИЧЕСКИЕ
ИНФОРМАЦИОННЫЕ СИСТЕМЫ
ДЛЯ МОНИТОРИНГА ХИМИЧЕСКИХ
ВЕЩЕСТВ В ОКРУЖАЮЩЕЙ СРЕДЕ:
БИОФИЗИЧЕСКИЙ ПОДХОД**

Е. М. Ключко

Институт экспериментальной патологии,
онкологии и радиобиологии
им. Р. Е. Кавецкого НАН Украины, Киев

E-mail: kelenaxx@ukr.net

Проанализированы новейшие биотехнические системы экологического мониторинга окружающей среды, основанные на использовании современных информационных и компьютерных технологий и имеющихся баз данных химических веществ. В частности, рассмотрены такие современные биофизические методы исследований, как имитационное и программное моделирование, учитывающие результаты автора, полученные в экспериментах с регистрацией хемочувствительных трансмембранных электрических токов в нейронах в режиме фиксации потенциала, применением флуоресцентных нейронных маркеров и подсчетом организмов-биоиндикаторов. Разработанные системы и методы позволяют выявить и идентифицировать опасные для живых организмов вещества и сделать выводы относительно их возможного биологического воздействия. Функционирование биотехнических информационных систем мониторинга окружающей среды проанализировано в широком временном диапазоне с использованием современных баз данных, экспертных подсистем и интерфейсов, способных идентифицировать различные типы химических веществ. Показано, что при таком системном экологическом мониторинге существует возможность изучать и прогнозировать последствия действия веществ на протяжении длительного времени — от первых моментов воздействия на отдельные клетки организма до месяцев и лет после воздействия на весь организм.

Ключевые слова: биотехническая информационная система мониторинга, загрязнение окружающей среды, биоиндикаторы, базы данных.

This work was done according to the State budget research work. "Processing of signals, images and data in electronic systems" 2010-2015, №63 / 08.01.01.